

Samp

2007

The HOUSE CUP introduced me to the Club
any as well as the Sports events. SYMP
overwhelming experience and I wish some
co-ordinate it.

Kshitij

2007

20th Issue

I spent all ground fun and frolic at
of life. For sure if you are
you would soon become one
great?

longer hidden showing at you for bread
a real restrained fun on how to go

K. J. Somaiya Institute of Engineering

Waranvihar, Mumbai- 400 077

ॐ

ॐ पूर्णमदः पूर्णमिदं पूर्णात् पूर्णमुदच्यते ।
पूर्णस्य पूर्णमादाय पूर्णमेवावशिष्यते ॥१॥

1. OM. Whole is that (Brahman), whole also is this (world). From whole comes the whole; take whole from whole; (yet) whole remains.

ॐ ईशावास्यमिदं सर्वं यत् किं च जगत्यां जगत् ।
तेन त्यक्तेन भुञ्जीथा मा गृधः कस्य स्वयंभनम् ॥२॥

2. OM. Whatever exists in this world is to be enveloped by God. (the Ruler). By renouncing it (the world) thou mayst enjoy. Do not covet the riches of any one.

मूकं करोति वाचालं पङ्गुं लघयते गिरिम् ।
यत्कृपा त्तमहं वन्दे परमानन्दमाधवम् ॥३॥

3. I bow down to Madhava, the Bliss Eternal; to Him whose grace enables the dumb to speak (and) the lame to go across a mountain.

ॐ पुणो देवी सरस्वती वाजेमिवाजिनीवती धीनामविश्रयवतु ।
ॐ चोदयित्री सूनृतानां चेतन्ती सुमतीनाम् । यज्ञं दधे सरस्वती ॥४॥

4. OM. May Sarasvati, the Divine, protect us by her strength-giving favours, she who is rich in strength-giving favours, the protector of our thoughts. Sarasvati, who inspires hymns and promotes pious thoughts, brings about our sacrifice.

ॐ असतो मा सद्गमय । तमसो मा ज्योतिर्गमय ।
मृत्योर्माऽमृतं गमय ॥५॥

5. OM. From the unreal lead me to the real, From darkness lead me to light. From death lead me to immortality.

ॐ सहनाववतु सहनौ भुनक्तु सहवीर्यं करवावहै ।
तेजस्यिनावधीतमस्तु. मा विद्विषावहै ॥६॥

6. OM. May God protect us both at the same time; at the same time support us both; May both of us at the same time apply (our) strength. May our learning be illustrious. May there be no hatred (between us).

सर्वेऽत्र सुखिनः सन्तु सर्वे सन्तु निरामयाः ।
सर्वे भन्नाणि पश्यन्तु मा कश्चिद् दुःखमाप्नुयात् ॥७॥

7. May all here be happy. May all be free from disease. May all see well-being; nobody experiences misery.

ॐ शान्तिः । शान्तिः । शान्तिः ॥
OM. Peace, Peace, Peace.

Message from the Founder



(Late) Padmabhusan
Pujya Shriman Karamshibhai Jethabhai Somaiya
16.05.1902 to 09.05.1999

*“न त्वहं कामये राज्यं, न स्वर्गं नापुनर्भवम् ।
कामये दुःखतत्यानां प्राणिनामार्तिनाशनम् ।।”*

*“Neither do I long for Kingdom, nor for heaven, nor do I desire to be free from rebirth.
I only wish to remove the sufferings of all beings afflicted by pain.”*

Our Trustees



Dr Shantilal K Somaiya
Vice - President



Late Shri P M Kavathekar
Hon Secretary
Somaiya Vidyapeeth



Samir Somaiya
Trustee



Smt Leela M Kozak
Trustee

Editorial



The intuitive mind is a sacred gift and the rational mind, a faithful servant. My magazine team began its work on the lines of this famous Einstein saying. Beginning with the House cup, to Symphony and now 'KSHITIJ', we have made a constant attempt to bring in some level of creativity in each of our endeavors while keeping the salient features set by our seniors alive.

It feels like just the other day that the badminton court was transformed into a workshop to facilitate the construction of the new building. And today, it is almost ready and functional. This has been a year in which our college has seen a lot of innovation and has been abuzz with activity; be it the festivals of the various committees or the race car designed by students of our college. We have taken another significant step in our journey of knowledge and learning. However, amidst all this, we have been left deeply shocked by the sudden demise of our beloved Shri P M Kavadiji, Honourable Secretary of the Somaiya Trust. We have lost a great patron of our college and an eminent educationist. On behalf of the Magazine Committee, I convey my profound condolences to his

family and pray to the almighty for the eternal peace of his soul.

Our college has a plenitude of talent in terms of prolific writers, articulate speakers, blessed artists and technically astute students. It gives me immense pride to bring forth their talent in the form of Kshitij 2007. Kshitij has been made keeping the 'Somaiyite' in mind. From interviews of professors to opinions of students, to a Somaiya quiz that helps us know more about our college, we have tried to include as many aspects of student life as possible. We have incorporated a section called "Seniors Speak" which addresses the common problems of students regarding CAT, GRE, placements etc and also provides some quality reading. In addition, we have included an interview with Captain Balbir Singh of the Indian Navy who shares his experiences with us. As a token of our respect and gratitude to the non-teaching staff with whom we are constantly interacting, there is a small piece in the Regional section to bring you face to face with a few of them. Check out the 'Seasonings' section for some interesting facts and college trivia. I express my sincere apology to those whose articles could not make it to the magazine.

Kshitij has been a combined effort. I wholeheartedly appreciate the efforts put in by the Joint Magazine Secretaries Sohiti and Rutvik as well as the entire literary team. I express my sincere gratitude to Mr. Milind Marathe and Ms. Usha Padmanabhan for their invaluable guidance. I would like to thank Madam Principal for her constant support. I thank Director Madam for her timely advice. I also take this opportunity to convey my gratitude to the alumni who have taken time out to write for us.

Happy Reading! Hope the experience makes a positive difference to you be it in a small way!

Sukanya Rajkhowa



Volume - 28
Published by
Somaiya Centre

Joint Magazine Secretaries
Sohiti Raina
Rutvik Sheth

Cover : Monil Gandhi

Drawings :
Aditya Kulkarni
Sangeeta Shirodkar

Joint Magazine Secretaries
Sohiti Raina
Rutvik Sheth

Cover : Monil Gandhi

Drawings :
Aditya Kulkarni
Sangeeta Shirodkar



Contents

Remembrances	3	More Than Words	
Director General's Message	5	Foreword	53
From the Principal's Desk	6	The Voices of our Gurus	54
Results 2006-07	7	Thou Shall Call Me A I	55
Placement 2007-08	8	Enliven My World	56
		Life's Like That	57
Reports		FAITH	57
General Secretary's Report	9	Freylin	58
Cultural Secretary's Report	10	Oscars and Indian Cinema	60
Sports Secretary's Report	11	Dine Out	63
CSI	12	The Hostel Fracas	64
EESA	14	Outrage	65
IEEE	16	Refugees in their own country	66
IETE	17	Feelings	67
ISTE	19	In A Lifetime	68
MESA	20	Love for My College	68
SAE	23	Waiting	68
SAHAS	24	Aloneness	69
TVM	25	A Patron of Art - Adolf Hitler	70
		Billionaires	71
Seniors Speak		A Trip to Kashmir	72
Report of the Students' Representative for Alumni Interaction	27	I Am Not Insane Neither Callous	72
Then & Now..... The period 1983-2007	28	Is Science Religion or Is Religion Science	73
Networking - A Bright Career Option	29	Awakening Indians to India	74
From The Horses' Mouths	32	Unrequited Love	74
		The Dead of The Night	75
Tech Treck		Edyukasion	75
Orion Racing:to Germany And Back	34	Shake Da World	75
Space Elevator-The Highway to Heaven	35	Fate	76
FOSS & Engineering	37	Rendezvous With Captain Balbir Singh	76
Application Of RFID In Education	38	Waddling Warriors - An FE's Corner	
OFDM-FLASH	40	My first days at KJSCE	77
Bluetooth V/s Wibree	43	Life at Hostel	77
Optimization of Interest Rates	45	BPO Industry	78
Tele-Immersion - Beyond Videoconferencing	47	Dying and Living	78
Our Picture of the Universe	48	God Where are you	79
The History of Plasma Display Panels	49	When	79
Will iphone repeat the success of ipod?	52	India after 60 years of Independence	80
		Say Yess Boss, But care for Juniors	81
		I	82
		Gods song to me	83
		Regional	83
		Art Gallery	93
		Students' Council 2006-07	97

Remembrances

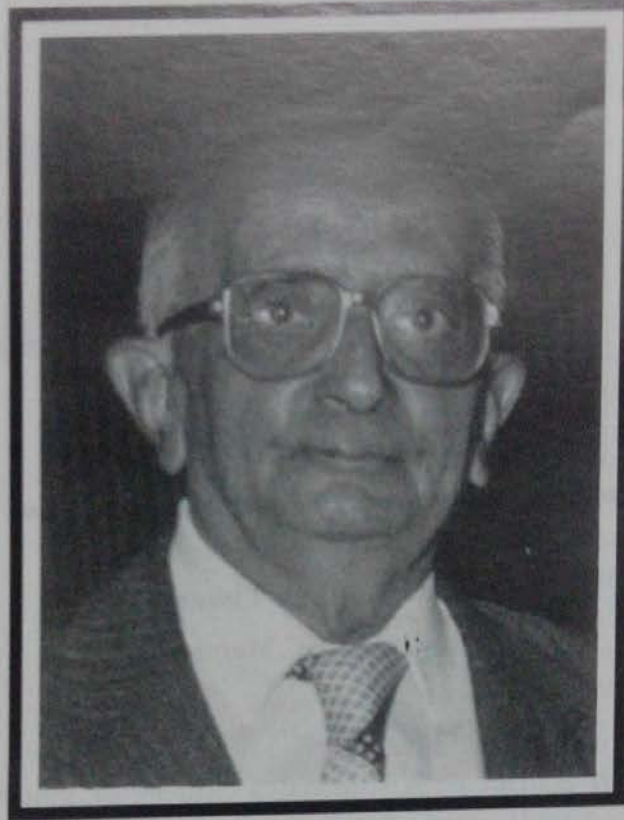

Pujya Shri Purushottam Mavji Kavadia

*Director, Somaiya Group of Industries,
Hon. Secretary, Somaiya Vidyavihar*

(17th June, 1918-16th August, 2007)

Just as this issue of 'Kshitij' was in the process of being printed, we were shocked to hear of the demise of one of the most revered and adored person, Shri, P. M. Kavadiaji.

With profound grief we the Director, Principal, Staff and Students offer our homage to Pujya P. M. Kavadiaji. This Institute and every individual in this Institute will miss him very much.

May his soul Rest in Eternal Peace.

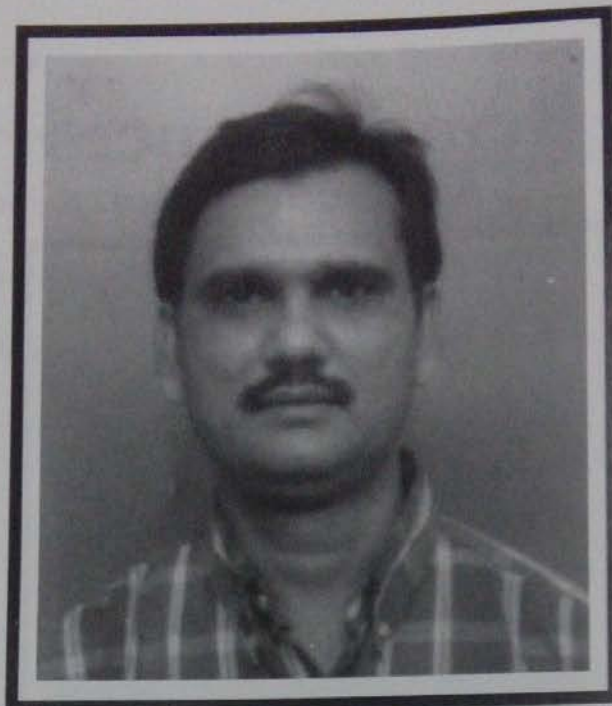

Jata Shankar Tiwari
15th July.1962 to 8th March, 2007

20 years of service to K J Somaiya College of Engineering.
(5th March, 1987 to 8th March, 2007)

Mr. Jata Shankar Tiwari was an active member of the Department of Mechanical Engineering as a Laboratory Attendant. He was hardworking and sincere to his work; a self starter with an open mind.

He was a role model for all Lab. attendants. He was very punctual in his work and used to complete the assigned work well in advance throughout his service in the department. He was popular amongst students for always extending an helping hand to them.

He was kind, gentle and well respected by the students, faculty and staff members as Tiwariji or Panditji. His absence will always be felt. May his soul rest in eternal peace.

Message

Director General's Message



Dr. (Mrs.) P. P. Parikh

For every Institute of learning, the release of its house magazine is a joyous occasion. The launch of "Kshitij 2006-07" is no exception. The contributions to this issue reflect a wide spectrum of talents from politics to technology. It brings to light the varied interests and imagination of the students. This magazine mirrors the true spirit of this Institute.

We, at Somaiya, believe that our duty to our students go much beyond merely turning into competent engineers who will build India of tomorrow: through continuous activities, we want to bring out integrated personalities with enlightened minds and profound human values, sensitivity to the country's needs and who are also capable engineers. Being associated with this College, I am able to contribute my insights to shape and form these young creative minds and I am proud of it.

I would like to convey to the students that they must harness their capabilities to the maximum extent, keep abreast with the advancing technologies, move with the progressing world, accept challenges and contribute to the national growth and development.

I congratulate the editorial team for this ensemble and I wish all the staff and students greater success in all their endeavours.

Principal's Desk

From the Principal's Desk



Dr. (Mrs.) Medha Dixit

The issue of Kshitij is released in the Silver Jubilee year of our College. The Engineering College started in 1983 with 180 students and in the last 25 years,

it has grown into a prestigious academic institute, with five disciplines and 2700 students. These 25 years have enriched us with lots of experience and memories.

Today I take pride in announcing some of our achievements in the year 2006-07.

- A group of students from our College who have themselves named as "Orion Racing Group" have fabricated a car Barracuda 600 which participated in the competition named "Formula Student Germany" held in Germany during August 08-12, 2007. This has been a maiden endeavour of the students of our College which has received appreciation from every nook and corner.

- Shortly we will be introducing Post-Graduate course for
a) Electronics Engineering and
b) Mechanical Engineering
- Our new building with a total area of 24,000 sq.m. will be ready soon and in the next semester Computer Engineering and Information Technology Departments will be shifted to the new building.
- In 2006-07 placements through campus recruitments was 514 (95%) with pay package upto Rs. 8.5 lacs per annum.

Now we have the Silver Jubilee year ahead of us. This will be a year full of challenges and opportunities for our students and staff. Now it is time to go beyond "Kshitij" the horizon we had set for ourselves and accomplish the targets successfully.

I congratulate the Student's Council and especially the magazine team for their team work and dedicated efforts. I wish all students and staff a happy and successful year ahead.

Results 2006-07

B.E. Semester - VIII

COMPUTERS

College Rank	Name	Percentage	University Rank
1	Phadnis Madhura A.	77.67	18
2	Doshi Sonam K.	76.93	31
3	Sanap Sagar Onkar	76.87	33

ELECTRONICS

1	Sawant Kamlesh K.	76.42	22
2	Banglorekar Tanmay D.	75.02	37
3	Mehta Kinjal A.	74.04	56

ELECTRONICS & TELECOMMUNICATIONS

1	Nayak Sridhar N.	82.62	2
2	Master Swati P.	80.69	13
3	Phadke Ameya Arun	79.72	19

INFORMATION TECHNOLOGY

1	Dabke Madhuri M.	74.00	41
2	Morbha Tejas D.	73.00	76
3	Khara Jignesh P.	71.87	114

MECHANICAL

1	Shrikhande Gaurang S.	81.50	8
2	Deshpande Aasavari G.	80.56	12
3	Kulkarni Shripad S.	78.44	19

DISTRIBUTION OF PLACED STUDENTS
BRANCHWISE

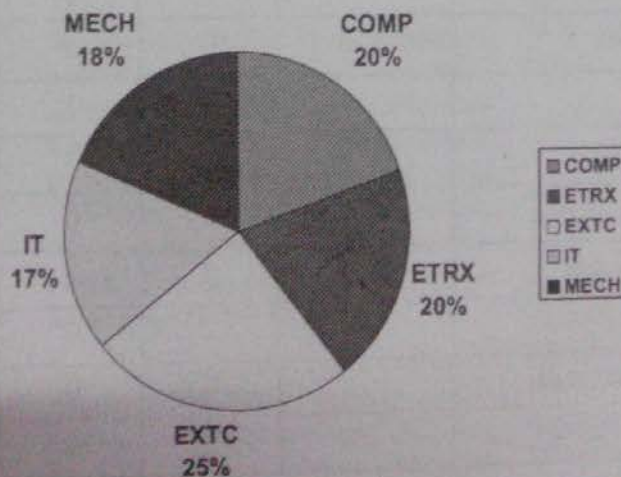

Placements 2007-08

No of Companies visited till date : 22
 Total Number of Students placed : 447
 % Placed : 60

	COMP	ETRX	EXTC	IT	MECH	TOTAL
Total Strength	154	145	154	144	146	743
Placed	87	87	114	76	83	447
% Placed	56.49	60.00	74.03	52.78	56.85	60.16

Sr. No.	Company	COMP	ETRX	EXTC	IT	MECH	TOTAL
1	TCS	51	21	49	22	8	151
2	Accenture	8	11	16	7	10	52
3	L & T	0	7	8	0	6	21
4	Geometric Soln	1	0	0	0	4	5
5	IFlex	2	3	3	3	2	13
6	Atos Origin	4	9	10	5	0	28
7	Mastek	6	4	4	5	0	19
8	Capgemini	4	7	8	9	0	28
9	CITOS	2	4	4	1	0	11
10	JK Files & Tools	0	0	0	0	3	3
11	Tata Eleksi	0	4	1	0	0	5
12	L & T Infotech	3	7	7	6	0	23
13	M & M	0	0	0	0	5	5
14	Tata Power	0	0	0	0	4	4
15	Infosys	1	4	1	4	8	18
16	Satyam	3	4	3	9	8	27
17	Godrej & Boyce	0	0	0	0	9	9
18	Schlumberger	0	0	0	0	5	5
19	PCS	1	2	0	2	0	5
20	Dow Chemicals	2	0	0	3	2	7
21	Reliance Energy	0	0	0	0	9	9

Report

General Secretary's Report

Success. What is success? How do you define success?

It was a surprisingly sunny August afternoon when our council was announced and I came to know that I was the first girl General Secretary in the history of Somaiya. Was that success? Maybe.

Our council got off the mark pretty quickly. Frequent council meetings helped us bond and we were all geared up by the time the first event came up, the freshers' eve. After two years of getting cancelled, the freshers' eve finally happened. The cultural team, the bands, the security team all rose up to the occasion and the function went off well. Perhaps that was success.

Even as we were getting settled in our jobs, the dates for Symphony 07 were announced. The festival was scheduled more than a month in advance! Multitasking took a new meaning as we started work for Symphony even as other events were going on. Thanks to the dedicated efforts of the council members, we not only managed to put up a good show on the teachers' and engineers' day and the house-cup but also the various teams and committees were ready by the time the odd semester ended. The enthusiasm of the juniors really surprised me and Symphony 07 had the biggest work force in recent years. Over 850 students. Success?

Organizing any event is a challenge. But when that event involves a lack of time, dearth of funds and not to mention inherent constraints of being students, it becomes a whole new ball game altogether. The judgment on Symphony 07 was passed the minute it was known that Informalz had been cancelled. But we took it up as a challenge. Symphony had to mean and it does mean more than this one event. With this one belief the various teams started work for the festival.

The biggest challenge we faced was to get people interested enough to come to the festival. The responsibility of this task was given to the publicity team, headed by Mona, and they performed splendidly. Symphony 07 saw unprecedented participation in all the events.

This year, with the grand exhibition by the INDIAN NAVY, we completed the trilogy started off by our peers. The exhibition was very well received by the students and faculty. It was a grand success.

Writing about Symphony is like writing about a lifetime of experiences in a few sentences. The creativity of the organizing team and their sheer dedication really amazed me. We went through it all while organizing the festival. Ups, downs, despair, excitement, fights, make-ups everything. And at the end of it all a quiet sense of satisfaction at having achieved what we set out to. And that's when I got my answer.

Success is THAT small sense of satisfaction at the end of the day.

Success is having been there and having the courage to have done it. Success is your knowledge that you have given the best you can under whatever circumstances you faced. Success is knowing what you did was the right thing to do despite what people might say.

Success is not defined by the number of people who danced at Informalz, success is defined by a filled auditorium for a first time cultural event. Success is an enviable line up of cars and bikes in an auto-expo of a college. Success is a full participation in all the literary events. Success was the 2000 people who enjoyed at the pronite...

So yes, I think ours was a successful council. My team worked under tremendous constraints and each and every one of them delivered what was

expected of them.

Nishant along with the infra chiefs handled the infrastructure, security and police permissions tactfully.

Shashank, the marketing chief got the team functional by the time we started work.

Riddhi, the marketing co-chief, showed that money can be brought in without contacts. She started the tradition of sending regular newsletters to the alumni which has been appreciated by all.

Sukanya along with Sohit and Rutvik organized some refreshingly new literary events.

Sharanya, Saqib and Karthik put up a great cultural show, one of the best in recent years.

Tojo made the perfect media chief and also came up with some good ideas for the Navy exhibition.

Monil and his technical team were a repertoire of brilliant ideas. He also pulled off a fabulous auto-expo.

Pranshu, Rishi and Aashish gave a new dimension to the even semester by conducting a Sports cup.

I take this opportunity to thank Rear Admiral V Balachandran for taking out time and gracing our festival with his esteemed presence. I also thank Captain Balbir Singh for his efforts to make the exhibition a success. I am very grateful to Chaudhary sir and ISTE for their help.

I express my gratitude to Arati Phadke madam without whose help, constant support and encouragement we could never have pulled this off. I thank Principal madam for her guidance throughout the year. I thank Director madam for her timely advice. I thank Mr. Dhanvi for his help and support. I also thank all the faculty and the non teaching staff of our college for their support.

Cultural Secretary's Report

My report is not complete without mentioning the infra and security chiefs and co-chiefs. The commitment displayed by these guys was really inspiring and the festival would not have been possible without them.

On a personal front, being the GS of the college was one of the most enriching and enthralling experiences of my life. It is quite clichéd to say this but I have learnt a lot from my tenure. Time management, anger management, multitasking, budgeting are only some of many many things. I have strengthened old bonds and made new ones too.

To conclude I would like to say that I think I had one of the best teams to work with. It was a pleasure and an honor to lead them. To the juniors I simply say this, whatever be the constraints, there will never be an experience that can beat being a part of the Students' Council. Keep the Somaiya spirit high because at the end of the day,

Who are we, who are we?

KJSCE KJSCE

How are we, how are we?

Very sexy very sexy!!!!

Rajapriya Sambandam



It is hard to believe that I am looking at my association with the Students' Council in retrospect. It feels like yesterday when I was handed over this post. The past year has been a rollercoaster of emotions and probably the most eventful year of my life.

Cultural activities for the year 2006-2007 started with organizing the fresher's party and teachers' day celebration followed immediately by house-cup part 1. The former two were relatively easy to organize but the latter involved a lot of preparation. Despite all our efforts one of the musical events was a complete nightmare. A technical malfunction brought the event to a standstill. Every attempt to rectify the problem was in vain, but the crowd seemed to enjoy themselves and their relentless mocking left us helpless and harrowed. But as I look at it today I realize this is what college life is all about; having fun with friends, catcalling along with the crowd and making the best out of every situation. If I were a part of the audience I would have probably done the same.

This experience however made us doubly careful with Symphony where every detail was given attention. Symphony took months of extensive planning from deciding on the theme which was "The village", to approaching a choreographer for gyrations, to deciding on workshops, devising a plan for publicity, deciding on events, event heads, judges, prizes and more. Publicity and event preparation hurtling at top speeds led to the highest participation ever in the events of Symphony. Even though "moving crowd" was less for reasons of its own, events were jam packed. For the first time eve, other colleges participated in fine arts events, musicals gorged on its fair share too. College was a buzz with 40 teams running helter-skelter for treasure hunt. The Dramatics Competition which happened for the first time ever in Symphony, and the

Ethnic Show drew a large audience, one which the auditorium was unable to accommodate.



Gyrations was a perfect concoction of tough competition and great entertainment, ending on a high note with our college bagging the first prize.

Symphony was a result of team work. I can't go without thanking the joint Cultural Secretaries Saqib who is probably the best compere in the whole college and Karthik who was always brimming with enthusiasm. I am also very thankful to the Gyrations Chiefs Abhijit and Akanksha, The Arts Committee Chiefs Priyanka, Sangeeta, Aditya, and the Musicals Chiefs Abhishek and Ashwini, all the event heads and each and every volunteer. In spite of the various constraints imposed on us, may it be a shortage of time, monetary issues or workforce, the Cultural team delivered and I am proud of it. I am very thankful to all the Infra and Security Chiefs who ensured that our events ran smoothly as planned. I also express my gratitude to members of the faculty, teaching and non-teaching staff who supported us.

Work continued even after Symphony, which wrapped up with B.E. farewell and the prize distribution. Besides this, sending our college teams to other college festivals during the course of the semester was in process. Our Gyrations team did us proud by winning in 7 out of the 8 colleges in which they participated, creating a record for Somaiya. Credit goes to the Chiefs and all the dancers. Hats off guys!

Today as I assay my experiences, reminiscence makes me realize no matter how much one complains about lectures and college, one has a sense of belonging to this college, a strange patriotism which surfaces when one is



amongst students from other colleges. Probably this is why one gets to see so many students involved in the activities of college, such large workforces, so many councils and so many events. It is this spirit which makes college life enjoyable and memorable. As a piece of advice to the future councils to come, never give up on a festival or an event irrespective of the constraints imposed, as it is this which defines your life as a student and adds one more dimension to your character. As our Principal rightly said during the Symphony inauguration, "Students will more fondly remember the 3 days of Symphony than the engineering formulae."

Sharanya Santhanam

Gyrations' Saga

1st Prize:

K J Somaiya College of Engineering, Vidyavihar

K J Somaiya College of Information Technology, Sion

Sardar Patel College of Engineering

Parshavnath College of Engineering

2nd Prize:

Lokmanya Tilak College of Engineering

Atharva College of Engineering

SNDT

Sports Secretary's Report

It is really amazing to realise how time flies. It still appears to me as if it was only yesterday that the Students' Council was formed. From day one we knew that it is going to be really difficult. The fact that the workshop building was brought down meant sacrificing the Badminton court, the Boys' common room and the White House to accommodate classes. Though it seemed tough at that time, today I can proudly say that none of them proved to be a hindrance at all. All this has been possible because of the efforts of a few people who I would like to thank whole heartedly. Firstly, I would like to acknowledge the constant support received from our Sports Incharge Prof. Yelvale who helped us in every possible way to carry forward all the sports activities. Further, I would like to thank the Joint Sports' Secretaries, Ashish Sheth and Rishi Malik, for having worked with great devotion and dedication tirelessly throughout the year. I would also like to thank my colleagues R. Shivakumar, Karthik, Saugandh, Ameya, Pratik, Kaif, Sachin, Ayank, Aniket, Revanth and all others who have helped me organize the various sports events throughout the year.

This year saw some excellent performances from our students in the tournaments organized by Mumbai University and in the various other inter-college tournaments. Some of the commendable achievements are as follows:

State level Inter-college tournament

COEP (Pune) organised a state level inter-college tournament at Pune. Three teams from our college participated viz. Football, Badminton and Basketball. It is really heartening to inform that our Football team secured 2nd position among all the colleges in the state of Maharashtra. Also, our Badminton team reached the quarter final stage in the tournament.

Mumbai University

Football: The football team registered a quarter final berth showing a splendid performance among 72 other participating colleges.

Handball: The handball team also secured a quarter final berth. Furthermore, our team was the only team from an engineering college among 72 participating colleges.

Inter college sports tournaments

1. **Football** - The Football team secured 1st position in tournaments held at KEM and D.Y. Patil Medical College. It secured 2nd position in the inter-college tournament in TSEC and 3rd position at SFIT

2. **Badminton** - The Badminton team secured 1st position in tournaments held at VJTI, ICT and KEM Medical College.

3. **Basketball** - The Basketball team secured 2nd position in the tournament organised by Fr. Agnel (Bandra), Thakur College and KEM Medical College. The team also secured 3rd position in VJTI and TSEC.

Intra college sports events

1. **Monsoon Cup** : An intra-college tournament was organised during the odd semester called "Monsoon Cup". The following events were organised during the tournament.

1. Football
2. Volleyball
3. Table-Tennis
4. Carrom
5. Chess

2. **House Cup (Sports week)** : The Intra college festival of our college, the "House Cup" was held in two phases

this year. While the cultural and literary events took place in the odd semester, the sports events of the House cup were organised in the even semester over a week. The following events were organised:

1. Box Cricket(Boys)
2. Box Cricket(girls)
3. Football
4. Table Tennis
5. Volleyball
6. Chess
7. Carrom
8. Darts
9. Tug of War(Boys)
10. Tug of war(Girls)

I would like to thank all the event heads, volunteers and the Infra team for performing their roles perfectly during the House cup and the Monsoon Cup.

I would also like to appreciate the willingness of all the sports teams to participate in other college tournaments despite the 75% compulsory attendance and other constraints faced.

Last but not the least, I would like to thank the entire Students' Council and Prof. Arati Phadke for supporting my decisions throughout the year.

Pranshu Sharma



CSI-KJSCE Council 2006-07 Report



Prof. Uday Joshi	Chairperson, CSI-KJSCE
Prof. Deepak Sharma	Faculty In-charge, CSI-KJSCE
Prof. Manish Potey	Faculty In-charge, CSI-KJSCE
Bro. Pankhul Maru	General Secretary
Bro. Aviraj Ajgekar	Jt. General Secretary
Sis. Hiral Mavani	Jt. General Secretary
Bro. Aditya Joshi	Secretary
Bro. Mihir Kachalia	Treasurer
Bro. Vivek Radhakrishnan	Technical Head
Bro. Shashank Agarwal	Event Manager
Sis. Ruchita Gupta	P.R.O.

We, as the CSI-KJSCE Council 2006-07, had a major objective before us throughout our tenure. It was to come up with quality events that would take the nascent CSI a step ahead and to keep the graph scaling upwards. We feel we have been successful in doing so.

The second year of the Computer Society of India-KJSCE chapter (which we lovingly abbreviate as 'CSI-KJSCE') boasts not only of unique events organized by the Council but also due to the innovations they brought about in these activities. The year was dotted with events like a film screening, competitions and seminars, not to mention 'Tatva-Convergence', the festival that marked the end of the year for CSI-KJSCE.

The events that were organized during the year were:

In the beginning of the odd semester, we organized a **seminar on Certification**. Our speaker for this seminar was Prof. Uday Joshi, Coordinator, CRPQA. The seminar spoke of the different certifications available and the doors they could open for a computer engineer. We also had a **Documentary screening session**

where three documentaries were shown before a full-packed auditorium. CSI-KJSCE was also associated with Somaiya Tadmaya Vyakhyanamala Lecture by Dr. Arvind Kudchadker. During the college festival Symphony, we organized **Bug buster - a C debugging competition**. A total of 43 teams participated in the competition.

In the even semester, CSI-KJSCE organized, in co-ordination with Dept. of Information technology, a **seminar on Virtual Reality** by Mr. Dinesh Saroder, Scientific Officer, BARC, Mumbai. We also organized a **PC Assembly competition in association with Intel and Gigabyte Technologies Limited**. A total of 46 teams appeared for the written elimination rounds. The five teams that were selected for the final round had to assemble the components given to them into functional PCs. Freebies were also given by Gigabyte technologies to the members of the audience who participated in the Quiz.

TATVA - CONVERGENCE 2007: Tatva-Convergence 2007 was held on 7th April, 2007 in K J Somaiya College of Engineering, Vidyavihar. It was

organized in association with the Departments of Computer Engineering and Information technology. The uniqueness of the festival was the participation of faculty members of the two departments in organizing the events. Each event was guided by a Faculty In-charge who ensured its smooth functioning.

As pre-festival events, three competitions were organized - Certificate designing (for FEs and SEs), Website designing (for TEs) and Flash Presentation designing (for Bes).

Events in Tatva-Convergence 2007:

1. Somaiya Tadnya Vyakhyanmala: A lecture on 'Tommorrow's IT and Business World' was delivered by Shri. Achyut Godbole, M D, Softexcel Technologies Ltd., in the Auditorium.

2. Project Poster Exhibition: The Project Poster Exhibition was held from 1pm onwards. All students from the final year of Computer Engineering and Information Technology participated in this event by presenting posters of their final year projects on the frames set up for them.

3. CV Writing Seminar: A

presentation was made by Cognizant Technologies Ltd. in the Einstein Room. The scope of the presentation was 'cracking interviews and writing a good CV'.

4. Battle-it-out: 'Battle-it-out' was a technical debate competition held from 2pm to 4pm. There were a total of nine participants who battled-it-out in two rounds.

5. PC Pathshala: The participants were taught to assemble a computer from its components. A batch of four-five students worked on a computer - there being eight such computers to be assembled. Each of these batches was guided by a student co-ordinator. A total of 41 participants attended the event.

6. Fun Arena: The Fun Arena consisted of events like a Food Quiz, a Sudoku competition and Football Quiz. They were conducted throughout the day at different locations in the college.

7. Technical Paper Presentation: Six teams presented their papers on different topics in the Einstein Room.

8. Photography Workshop: Photography Workshop was conducted

in Room no. 120. The speaker at the workshop was Mr. P. K. Bhatia, a distinguished and senior photographer who spoke at length about the technological advances and techniques of photography.

9. Vroom: Vroom was a Robotics event that was held in the Centre Quadrangle of the college throughout the day.

10. Linux Workshop: The Workshop was co-ordinated by Bro. Aviraj Ajgekar. The participants were taught installation of Linux and basic programming and compilation in C++. They were also given Ubuntu Linux CDs for free.

11. Technical Treasure Hunt: This unique competition tested the participants for vital computer knowledge. The elimination round consisted of written questionnaires that were handed out to all the participants. After this round, they had to debug C programs followed by certain Windows Related practical questions.

All in all, it was indeed an eventful and fun-filled year for the CSI-KJSCE Council as well as the members and the participants!

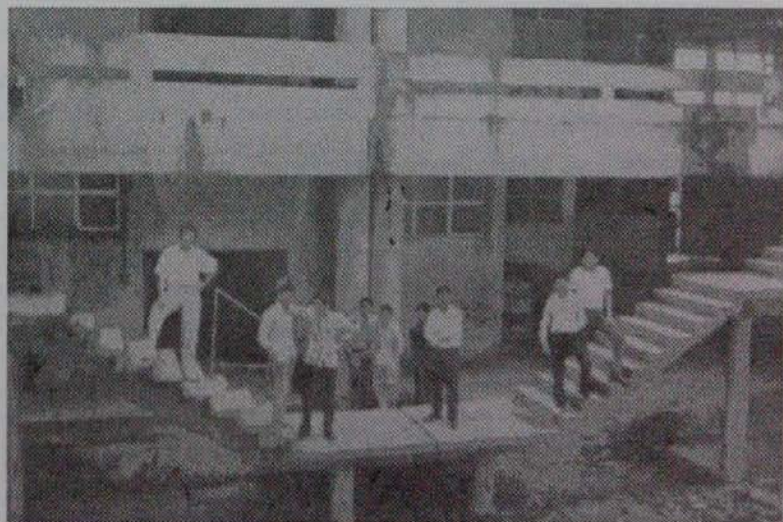

Look for Phadke madam's and Choudhry Sir's cabins!!

This was college about 20 years back.. KJSCE has gone a long way...we dare complain!!

Electronics Engineering Student's Association

Department of Electronics Engineering

Subject: Technical Film Show

The first event of EESA in the year 2006-07 began with a technical film show which was a Documentary on TESLA which was conducted at the auditorium on August 05, 2006. The event began with an inaugural function attended by Vice Principal Mr. Anil Thosar, Mrs. Annu Abraham and Mrs. Arati Phadke.

Then Jay Phatak, a student of B. E. (Etrx) was felicitated by the Vice Principal Mr. Anil Thosar for scoring 1600/1600 in GRE. Finally the educational clip was shown.

Subject: Report on Cricket Quiz 'HOWZATT'

A cricket quiz 'HOWZATT' was organized by EESA on the 26th August, 2006. But this did not have to be any other quiz contest. It had to be one with a difference. The response we got was great. Thus the quiz was a Virtual Cricket.

Subject: Report on Training & Placement

A job recruitment orientation programme was held by the EESA council with the assistance of senior students and faculty members on the 16th of September, 2006.

A few BE students who have been placed with reputed companies briefed the third year (TE) students about the various details of the selection process such as eligibility criterion, aptitude tests, group discussions & the personal interviews conducted by the companies who visit our college every year.

Lecture Series on Design Aspects and Practices Theme

There are many topics included in the curriculum of university syllabus in which the designing of various circuits / systems is involved. While designing it is necessary that one should be aware of the practical aspects. The following

aspects of the design were discussed during the lecture series.

- Data
- Assumptions
- Design Procedure
- Testing / Grading / Validation
- Practical Problems
- Realization

Faculty members from various AICTE / UGC / DTE approved engineering colleges / polytechnics can apply for the same.

Lan Gaming

The Electronics Engineering Students Association organized the event of LAN GAMING during the college festival 'SYMPHONY 07'. The event witnessed an overwhelming response from students from our college as well as other colleges. The competitions held included:

- 1) Counter Strike
- 2) FIFA 07
- 3) Need For Speed-Most Wanted.

Console Gaming

The Electronics Engineering Students Association organized the event of CONSOLE GAMING during the college festival 'SYMPHONY 07'. The event witnessed an overwhelming response from students from our college as well as other colleges.

Off Campus Treasure Hunt

An Off Campus Treasure Hunt Contest was organized by EESA on the 2nd February 2007 during the Annual Collegiate Festival 'Symphony'. The teams had to cover the areas of Kalina, Bandra, Dadar, Worli & back to College sequentially.

TPP

EESA council organized the inter college TECHNICAL PAPER

Faculty In charge:
Prof. M.S. Marathe
Prof. Annu Abraham

General Secretary:
Jignesh Malde
Treasurer:
Anand K.S.

Joint Secretaries
Kshitij Badani
Chirang Solanki
Srividya Venkar
Devesh Dedhia
Prachi Thapar
Akash Narayanan

PRESENTATION for Symphony 07 held on 3rd Feb, 2007. The presentations of the students were judged for their innovativeness, clarity of thought, and practicality of the idea and presentation skills.

Report on: EESA Sports Week

A week long series of sports activities were held for the electronics students right from FE's to the BE's as part of the EESA Sports Week.

Events such as carrom, chess, football, table Tennis were conducted. The students were really enthusiastic about participating in these events and winning points for their respective divisions.

Potential 2007

The Department of Electronics Engineering and Electronics Engineering Students Association (EESA) organized one day Festival named POTENTIAL 07 on 17th March 2007.

Inauguration:

Potential 07 was inaugurated at 9.30 a.m. in the Auditorium by Mr. Amit Rao (Software Architect, MPHASIS).

FE/SE & TE Project Competition

"Project Exhibitions and Competition" was organised for FE-SE level.

The judges gave marks based on performance, scope and application of project. Special Prize was awarded to Mr. Yash Mulgaonkar for Magnificent display of project on Aircraft and Spybot.

BE POSTER Presentation / Competition.

Total 56 groups participated in this event. The judges observed all the posters very keenly and quizzed all participants. The judges gave marks based on performance, scope and application of project.

BOOLEAN ALGEBRA

C-APPLICATION

FOX HUNT

The aim for the participants was to find a hidden transmitter in the college building by using receiver sets given to the teams.

Manager's Desk

This event concentrated on the marketing, logical reasoning, creativity and general awareness of the corporate world.

It had three rounds:

- 1) AD BLITZ
- 2) BRAND EQUITY
- 3) MERGER AND ACQUISITION

Seminar- What Industry Expects From The Students

The main objective of the event was to have an interaction between Industry & Third year student who are joining for placement in the month of June.

Three speakers were invited

1. Mr. A.B. Bhanage.
Sr. vice president (Sales) Aplab

2. Mr. Vijay Sonavane
Vice president (HR) Melstar

3. Mr. Rahul Deshpande
Project Manager (Accenture)

They gave an idea about what hardcore industry expects from students as well as career in software industry & after graduation (MBA,MS) Our alumni shared his view about career in software industry.

Chakravyuha

"Chakravyuha" had eight games which checked the mental and physical ability of the team. Each team had to play the following games:

Anagrams, Slope Cycling, Junkyard,

Block Building, March Weight, Blind Robotics, Libra

Robotics

Also a Robotics (Level 1 Track) was organized for students of all branches. Around 15 teams had participated each team comprising of 3 to 4 members.

EESA Industrial Visit 2006-07

In the academic year 2006-07, EESA had organized an Industrial visit to Uttaranchal from 18th December, 2006 to 26th December, 2006. 71 students of third year accompanied by 4 staff members of the Electronics department had participated in the visit. The tour was a good combination of 'knowledge' and 'Enjoyment'.

Detailed report is as follows.

18th December, 2006: Students assembled at Dadar Terminus and left Mumbai for Delhi via Dadar-Amritsar Express at 11:30 PM

19th December, 2006: Train journey

20th December, 2006: The group arrived at H.Nizammudin at 5:00 AM and checked into the hotel. After breakfast the group left for Industrial visit.

Industries which were on visit are as follows,

- 1) Maruti Udyog Pvt Ltd, Gurgaon:
- 2) HPL India switchgears Ltd., Gurgaon:

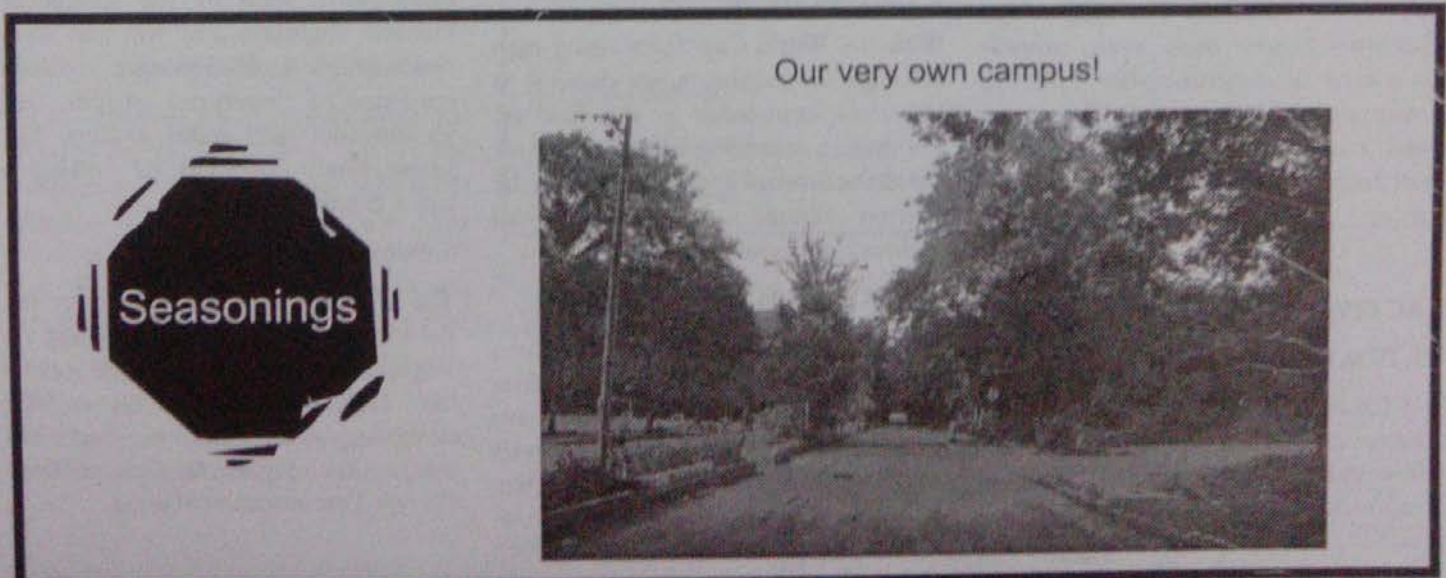

IEEE Report 2006-2007



IEEE COUNCIL:	
<i>Chairperson</i>	Sahil Sanghvi
<i>Vice-Chairperson</i>	Sanket Doshi
	Sanket Bafna
<i>Treasurer</i>	Anushree Gandhi
<i>Joint Treasurer</i>	Ruchit Mehta
<i>Secretary</i>	Zainab Burmawalla
<i>Joint Secretary</i>	Aditi Parekh
<i>Publicity Head</i>	Bhavik Parekh
	Abhinav Madan
<i>Marketing Head</i>	Siddharth Sirgiri
	Anusha Subramaniam
<i>Event Coordinator</i>	Shail Sanghvi
<i>Literary Head</i>	Neha Agarwal
<i>Webmaster Head</i>	Amit Parmar
	Anant Garg
<i>External Affairs Coordinator</i>	Sagar Dumbre
<i>Editor</i>	Shubhra Vatsal

IEEE-KJSCE chapter has yet again set new trends and benchmarks and successfully achieved the high targets we set for ourselves. The chapter has become bigger than ever, proudly boasting its membership of 193 members, the highest ever! The quality and range of events organized has certainly left the students asking for more.

ACTIVITIES:

1. IV to Chandigarh-Shimla :

IEEE-KJSCE could not have had a better start than a successful Industrial Visit to Chandigarh-Shimla. The visit to industries like Swati Storevel Limited, HFCL, Shiva International gave us rare insight into different manufacturing

processes. Also, it was a good break for students after the exams.

2. Football Trivia :

With the World Cup fever rising high amongst the engineers, we decided to test their knowledge in the field of Football by arranging an exclusive quiz for all the football lovers. Along with the written eliminations, we also had various audio-visual rounds.

3. TRYST-2006 :

'Robotics : Level 1, 2, 3 ; T.P.P. ; Da Vinci Quest and India Talking ' - the four major events of Tryst-2006. We have truly broken the notion that festivals can be arranged only in even semesters because this odd semester Intra-collegiate festival got an amazing response.

4. Mock C.B.I. :

IEEE-KJSCE decided to check the investigative skills of the technically inclined engineers and we sure were overwhelmed. Elimination rounds consisted of fingerprint analysis, face identification and audio mystery. The grand finale consisted of solving a mock Bomb Blast case.

5. Pentathlonline :

The first ever online festival arranged in the history of K.J. Somaiya College of Engineering! We had technical events like Technical Treasure Hunt, Web designing event and non-technical events like Figure it Out, Picture Perfect, Documentary Making.

6. IV to Rajasthan :

To attain the quest of enhancing and fostering interaction between its members and the industry, the chapter arranged an Industrial Visit to Rajasthan. We visited industries like Bajrang Wires and Ball Bearings, Jaipur Pottery and Ceramics Limited.

7. 360 degrees -2007:

"360 degrees-2007"—one thing that the entire IEEE council will agree on is that it has been a perfect rollercoaster ride...a circle full of joys, expectations, worries and new experiences! We had events like Technovista, Circuit Me This, Console Gaming and the ever popular Crystal Maze. Also, Bar Camp was arranged this year which is an ad-hoc un-conference born from the desire for people to share and learn in an open environment. A Job Mart was arranged which had companies like KPMG ,Vegagyan ,Stock Holding Corporation of India limited, Race Infotech coming in to offer jobs and internships to students. We also had activities like Karaoke, Pottery Making, Just A Minute games, Tarot Card reading and Scavenger Hunt for the entertainment of students.

8. Rocketics:

A technical event which surely surprised people because we had participants making rockets out of mere plastic bottles. A compressor was provided. The winner was decided on the basis of time of flight.

9. Wanna be the Next J. K. Rowling :

It was an event arranged exclusively for Harry Potter fans. The 1st round consisted of a Harry Potter quiz while playing a live game of chess. The finalists had to present their version of J. K. Rowling's 7th book, giving them a rare chance to be J. K. Rowling for a day!

All in all, it has been a successful year. We would like to thank Prof. Arati Phadke for her tremendous support and encouragement throughout the year.



I.E.T.E Report

I. E. T. E. COUNCIL 2006 - 2007

<p>Senior Council</p> <p>Prof. S.S. Thakur <i>(HOD, E&T dept, K.J. Somaiya C.O.E.)</i></p> <p>Prof. Jayshree Kundargi <i>(Secretary)</i></p> <p>Prof. Maruti Zalte <i>(Treasurer)</i></p> <p><i>Chairman:</i> Rounak Moundra</p> <p><i>Vice-Chairman:</i> Hiten Jain & Rajeev Vasani</p> <p><i>Joint Secretary:</i> Prajakta Chaudhari Nikhil Suryanarayan</p> <p><i>Joint Treasurer:</i> Anushree Khandalkar</p> <p><i>S.E. Co-ordinator:</i> Shishir Srivastava Rishikesh Ashar</p>	<p><i>Editor:</i> Shubham Goyal</p> <p><i>P.R.O.(t):</i> Jaydev Doshi B. Prashantkumar</p> <p><i>Event Co-ordinators:</i> Hardik Madia Hardik Gogri Ashwin Nair</p> <p><i>Website incharge:</i> Ankit Tripathi Junior Council (S.E. Students) Shruti Dedhia Ashutosh Chaudhary Narayanan Seshan Aditi Vira Nilesh Kasar Rajgaurav Khare</p>
--	---

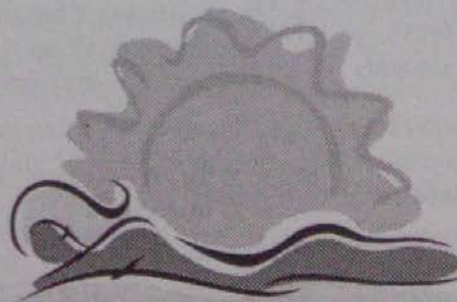

ACTIVITIES FOR YEAR 2006 - 2007

1) Seminar on Studies abroad by Madhavi Desai

The seminar on scope of studies abroad was conducted in KJSCOE by Madhavi Desai, a reputed columnist and counsellor. She elaborated each and every aspect of studying abroad in a very lucid manner. The seminar was attended on a huge scale by TEs and Bes.

2) Junior Council Interviews

IETE has been consisting of a junior council right from its inception in order to have a better interaction with newly introduced second years to dept of EXTC. To keep up with this tradition, Students from second year (SEs) were interviewed by a panel consisting of professors and IETE senior council members alike. Many students took the interview and the final selection was made on basis of their performance in the interview as well as their co-curricular activities.

3) Group Discussions for SE Students

More than 80 SEs participated in the event which consisted of elimination rounds, semi-finals and finals. Expert Faculty from EXTC dept and from the Science & Humanities dept judged the participants.

4) MATLAB workshop

The main aim of this workshop was to hone the skills of students in working in MATLAB environment. The workshop was attended in large numbers by TE students. The workshop would definitely help the students in their future projects.

5) Technical film show

Students from EXTC department attended the technical film show on the

following topics.

- (i) Black Holes
- (ii) Protocols and
- (iii) Sound

The show was very informative and was cherished by teachers and students alike.

6) Seminar on GSM Technology by Mr. Narendra Matange

A seminar on GSM Technology was conducted by Mr. Narendra Matange, Vice President, Hutchison Essar. The seminar was very interactive. Mr. Matange encouraged students to answer some of his basic technical questions. His unique methodology was well appreciated by teachers and students alike.

7) MEGA Quiz

About 40 teams comprising of 2 members each tested their wits in the ultimate quiz. The questions ranged from sports, literature, current affairs, history to logical reasoning. The filtered teams contested the finals which consisted of buzzer and rapid fire rounds.

8) Entertainment Quiz

Another quiz which tested the students for their general knowledge in the field of entertainment, Bollywood, Hollywood and so on was organized, where more than 60 teams participated.

8) Industrial visits

A local industrial visit to MTNL Chembur was arranged for the TE students to introduce them to basic telephone networks. Another industrial visit to Chandigarh-Manali was arranged, where the students visited a host of companies.

9) Aptitude test and Mock interviews

As a part of the regular activities conducted by IETE for the students of

the department, aptitude tests, mock interviews and seminars were held to help the students to walk through the placements.

10) PCB and Soldering Workshop

In order to give the students insight into the art of soldering, which is an integral part of electronic project development, IETE arranged a workshop for the SEs under the guidance of Prof. S. S. Thakur. The Workshop consisted of 3 seminars and 3 sessions of hands-on experience of soldering.

11) Seminar on Stock Market

A seminar on stock market and Indian economy was conducted by a final year student, Rounak Mondra. The seminar was conducted in 3 parts; introduction to stock market and Indian economic parameters affecting and controlling them and company analysis.

12) OSCILLATIONS '07

Oscillations'07, an intercollegiate festival, was organized by IETE students forum of 4 colleges under the IETE students chapter of Mumbai section; namely, K.J. Somaiya College of Engineering, Fr. Agnel College of Engineering, Bharti Vidyapeeth College of Engineering and S. S. Jondhale Institute of Engineering. A host of events like Robotics, Bombay Stock Exchange, Debug Zone, Fastest Computer First, Technical Paper Presentation, Project Display and Hang our name were organized on the 3rd of March.

13) SYMPOSIUM

SYMPOSIUM, the concluding event for the year was held on the 7th of April wherein all the department toppers, subject toppers, Oscillations'07 winners and council members were felicitated.



INDIAN SOCIETY FOR TECHNICAL EDUCATION

भारतीय तकनीकी शिक्षा समिति

ISTE Students' Chapter Report 2006-2007

Indian Society for Technical Education (MH-60)

Managing Committee

Chairperson

Mehul Rajput (TE ETRX)

Treasurer

Rishabh Srivastava (TE EXTC)

Members

Amev Amonkar (TE ETRX)

Rahul Rode (TE ETRX)

Jayesh Chande (TE ETRX)

Khushal Chandan (TE ETRX)

Piyush Agrawal (TE ETRX)

Pratik Tailor (TE MECH)

Sanjay Singh (TE MECH)

The ISTE Students' Chapter organized a series of events during its tenure varying from seminars and workshops to literary and quiz competitions. A list of events organized by the council

during the course of the year 2006-2007 is as given below:

Sports Quiz:

The sport quiz was organized on 28th January. The elimination round was a written test followed by the final round with four finalists. A total of 56 entries were received for this event. The winners were given cash prizes and all the finalists were given certificates.

Robotics:

The Robotics (Mud Track) was organized by us as part of technical events Symphony 2007'. An overwhelming response of over sixty teams was received. The winners were given cash prizes and all the finalists were given certificates.

Preplacement Programme:

A pre-placement programme was organized for the third year students who would be going for their campus recruitment. It was a complete package including an aptitude test, group discussions and personal interviews. The aptitude test examined the students in quantitative analysis, verbal and technical sections. In personal

interviews, experts were from the industry to guide the students about various interview techniques

Tadnya Vyakhan Mala:

As a part of TVM series we conducted a seminar on "Embedded Systems" by Rear Admiral V. Balachandran. As Embedded Systems is part of our studies, it was a great experience and through this seminar we got an overview of Embedded Systems and its future as an engineering field.

Technopreneur:

It was our one day fest organized on 17th March. The fest was a perfect mixture of technical, literary and fun events. The highlight of this fest was "Prakalpa" an intercollegiate project exhibition, first of its kind in Mumbai University. Another event was the Animation Workshop by C G Tantra which briefed our students about the latest techniques in animation, the softwares used and the scope of engineers in the world of animation.

The other events included a GK quiz (around the world in 8 questions) and a gaming event (football crazy)

2700 Languages spoken in the world

Seasonings

Today, there are more than 2700 different languages spoken in the world, with more than 7000 dialects. In Indonesia alone, 365 different languages are spoken. More than 1,000 different languages are spoken in Africa. The most difficult language to learn is Basque, which is spoken in north-western Spain and south-western France. It is not related to any other language in the world. Mandarin is the most spoken language in the world, followed by English. But as home language, Spanish is the second most spoken in the world.



MESA

Mesa Council for The Academic Year 2006-07

Parent Body		S.E. Representatives	
<i>Chairman</i>	Prof N.S.Chandrashekhar	<i>Div A</i>	Taha Mohammad
<i>Faculty Incharge</i>	Prof Manoj.A.Palsodkar	<i>Div B</i>	Sagar Rao
<i>President</i>	Akies Samson (B.E)	Associate Members	
Executive Body		<i>Seminars & Workshops</i>	Deep Bandivedkar
<i>General Secretary</i>	Swaroop Suvarna	<i>Industrial Visits</i>	Prakash Dary
<i>P.R.O</i>	Siddharth Desai	<i>Marketing & Promotion</i>	Vivek Shah
<i>Treasurer</i>	Chirag Thakker	<i>Publicity, Memberships & Tool Bank</i>	Sameer Kulkarni
Joint General Secretaries		<i>Technical Events</i>	Amit Patil
<i>Seminars & Workshops</i>	Vimal Radhakrishnan		Sagar Kunsalvkar
<i>Industrial Visits</i>	Sohan Kulkarni		Vinit Pujara
<i>Marketing & Promotion</i>	Rajiv Ved		Harish Sompu
<i>Publicity, Memberships & Tool Bank</i>	Heena Vyas		Shyamsunder K
<i>Technical Events</i>	Shreyas Vyas		Mehul Kaku
			Nimesh Manani
			Saurabh Bafu
			Ricky Botadra

INDUSTRIAL VISITS

Organizing Industrial Visits (IV) for the Students of Mechanical Department is one of the main objectives of MESA for which we have a dedicated IV team. This year MESA organized a total of 8 IV's as Follows:

1) Bharat Gears, Mumbra

An Industrial Visit to M/s Bharat Gears, Mumbra, was arranged on **22nd September 2006** for students of SE Mechanical. Bharat Gears specializes in manufacturing of all types of general Purpose & special gears & drive systems for varied industrial applications. 20 Students attended this IV.

2) Emkay Fastners, Thane

An IV to Emkay Fastners, Thane, was organized on **1st October 2006** for students of SE & TE Mechanical. Emkay Fastners specializes in Job Order Production & houses varied Hi-Tech & Precision machinery such as CNC Milling Machines, Boring & Drilling Machines & Lathes. The main

feature of the IV was that the students got to witness an EDM (Electro Discharge Machining) system in full operation. These machines are used for special precision jobs at high speed & are not available in all industries in Mumbai.

40 students attended the IV. Prof N.S.Chandrashekhar, HOD, Mechanical Dept accompanied the students to the IV.

3) Jindal Steel Works (JSW), Thane

An IV to Emkay Fasteners, Tarapur, was again organized on **24th Feb 2007** for students of SE & TE Mechanical. JSW is one of the largest Steel manufacturing facilities in Maharashtra & biggest around Mumbai region. The steel plant is spread over 44 acres housing several units of pickling, cold rolling, galvanizing and color coating of steels. The main feature of the Plant is that it has its own captive power plant generating 7 MW of energy. Thus the students got the benefit to witness the working of a Power Plant in addition to

the Steel Plant.

60 students attended the IV. Prof P.S. Yelpale accompanied the students to the IV.

4) Blue Star, Thane

An IV to Blue Star, Thane, was organized on **10th March 2007** for students of SE & TE Mechanical. Blue Star is one of the leading manufacturers of AC's, Water Coolers & various Cooling & Refrigeration Systems in India. 30 students attended the IV. Prof N.S.Chandrashekhar, HOD, Mechanical Dept accompanied the students to the IV.

5) Emkay Fasteners, Thane

An IV to Emkay Fasteners, Thane, was again organized on **10th March 2007** for students of SE & TE Mechanical. 25 students attended the IV. Prof Rajesh Pansare accompanied the students to the IV.

6) Kadana Hydro Electric Power Plant, Gujarat.

An outdoor IV to Kadana Hydro Electric Power Plant located in Panchmahal District in Gujarat was organized on **07th April 2007** for students of TE Mechanical. The Kadana Power plant is one of the largest Hydro- Electric Power plant in Gujarat. The main feature of the IV was that since the plant was under Maintenance the students got the rare opportunity to observe the different parts of the Kaplan turbine. 81 students attended the IV. Prof S. R. Bhandari; Prof Prashant Aphale & Prof S.N.Bansode accompanied the students to the IV.

7) Tata Power's Thermal Power Plant, Trombay.

An IV to the Thermal Power Plant located at Trombay was organized on **21st April 2007** for students of TE Mechanical. The 2000 MW Power Plant is run by TATA Power & is one of the main sources of supply of Power to Mumbai & Thane Districts.

24 students attended the IV. Prof Prashant Aphale accompanied the students to the IV

8) Tata Power's Bhewpuri Hydro Electric Power Plant, Karjat.

An IV to Bhewpuri Hydro Electric Power Plant located near Karjat was organized on **24th April 2007** for students of TE Mechanical. The 96 MW Power Plant is run by TATA Power & is also one of the main sources of supply of Power to Mumbai & Thane Districts.

40 students attended the IV. Prof Prashant Aphale, & Prof Rajesh Pansare accompanied the students to the IV.

SEMINARS & WORKSHOPS

MESA arranged Seminars & workshops on varied topics for the students as follows:

Seminars:

1) Six Sigma

A two-hour Seminar on Six Sigma by Mr. Ashish Kumar, Manager, M/s L&T

Ltd was arranged on **05th October 2006** for the final year students. Six Sigma is a technique by which an organization can effectively increase its efficiency & output & is widely used by many industries all over the world like GE Electric, Larsen & Toubro, Siemens, & Motorola. Many final year students also take it up as their project & the seminar was a great help for them.

2) Lecture Series by Larsen & Toubro (L&T):

A lecture series for Third Year students was arranged on **09th October 2006** and the details are as follows:

1) Introduction to L&T and its products and life as engineer at L&T by Mr. M. D. Maheshwar Campus Ambassador, L&T Ltd.

2) CAD/CAM & its implementation at L&T. by Mr. H. S. Ketkar

3) Product Life cycle Management by Mr. Anand Wankhede, Aluminous, KJSCE.

3) Memory Building:

A Seminar on "Memory Building" by Mr. Swaminathan, Ex- Professor, Fr. Agnel COE, Vashi

was arranged for first year students of Mechanical Department on **10th October 2006**.

OTHER ACTIVITIES

MESA Website:

This year MESA launched its own official Website: - www.mesakjsce.org. The objective of the website is to become a single destination for all source of information on all activities of MESA. The use of the website was tested by hosting all details about G-Force'07 & inviting online registrations of students from college all over Mumbai. The website will host all information about MESA, Dept of Mechanical Engineering & include Photo gallery, Discussion Forums & Latest Technical articles. The students of Mechanical Dept can also access useful data like Class Time Table, Syllabus, Attendance Records, and

Important Notices etc with the click of a Mouse

Tool Bank:

Tool Bank was started by MESA many years ago with the objective of providing costly Workshop Tools at a Subsidized rates mainly to SE students who have to work on lathes. These tools include Cutting & Tool of High Quality Triple Swastik HS-400 & HS-200 type of Miranda Company. Students are refunded a part of their money when they return their tools. These tools are then passed on to the next batch.

T-Shirt Design Competition:

Like every year designs were invited from all students of Mechanical to give their designs & ideas for a T-Shirt, which would be worn by the students themselves. After screening all the entries two designs were chosen which were combined to create a T-Shirt for the Mech Students. The T-Shirt was printed & made available to the students in February-07. Mech Students can be seen wearing this black T-Shirt in the campus.

Su-Doku Competition:

MESA began its activities for 2006-07 by organizing a Su-Doku Competition for the students on **14th September 2006** to test their skills in this interesting game. Students who used to solve this game in the newspapers as a pastime came out to play this game & win a cash prize. A total of 55 students participated in the competition.

All Mumbai MESA Council Meet:

A first of its kind meeting of Representatives of MESA Councils of different Engineering colleges in Mumbai was held at K.J.Somaiya on **07th October 2006**. Siddharth Desai, PRO, MESA-KJSCE convened the meeting. Representatives from Sardar Patel COE-Andheri, Fr Agnel COE-Vashi, LT COE-Koparkhairane, & Konkan Gyanpeeth COE-Karjat attended this meeting. The objective of the meeting was to start networking between the MESA bodies of different colleges & form a platform for sharing of Information & Expertise.

The MESA Technical Festival 'G-Force' was held for the second time on Saturday, 3rd March 2007. The MESA council made an effort to make the festival bigger and better than the last year. The council ensured that the essence of G-force, which is a Technical festival, would not be diluted by organizing non-technical events in the name of technical festival and at the same time the events were designed to test the technical process, skill as well as speed of execution of the participating students.

The various held during G-force'07 were

A) Technical Events

1. **Junkyard Wars** - A trademark event of G-Force, this year the event involved designing and fabricating a launching device from the given Junk Material.

2. **Tech Treasure Hunt** - A new event, which was a deadly combination of Basic Technical Knowledge & Physical abilities. The students had to cover entire Somaiya Campus and complete various tasks.

3. **Ad Blitz** - A totally new concept where students had to use their creative & Marketing skills to sell a product.

4. **Robotics** - It consisted of 3 tracks where students maneuvered their robotics i. Obstacle Track, ii. Robo football, iii. Dirt Track.

5. **Big Fight** - A debate competition that revolved around the subject of energy crisis, Load Shedding and Power Management.

6. **B. E. Project Presentation** - An event where B.E. Mechanical students presented their Final Year academic projects.

7. **Sci Quiz** - A quiz competition based totally on science from Nano-Tech to Biotech and scientists.

8. **TPP** - Students got an opportunity to present their technical papers on topics like cryogenics, automobiles, air-conditioning, IT developments etc.

B) Seminars:

2. **Vedic Mathematics**: A seminar in the use of Vedic Maths for the advantage of the engineers was organized mainly for FE & SE Students

3. **Natural cooling systems**: Seminar on Development of Eco-Friendly Natural Cooling Systems as an alternative to modern power consuming AC Systems was given by Mr. Surendra Shah, Ex-President, ISHRAE (Indian Society of Heating, Refrigeration & Air Conditioning Engineers) in the Auditorium.

C) Workshops:

1. **Heavy Machines workshop**: Heavy Road Construction Machines like Wheel Dozers & Cranes were displayed & their complex Hydraulic Mechanical Systems were explained to the students. Students were also given one of a kind opportunity to practically operate these Heavy Machines.

2) **AutoProduct Design**: Mr. Suvodeep Das, an Alumni of National Institute of Design-Ahmedabad, conducted a workshop on the subject. He gave a presentation on his designs of an Electric Auto Rickshaw which is now successfully running on the roads of Bangalore. He also displayed the working of several of 3D Modeling software like CATIA, IDEAS, and 3D MAX, which are used for detailed designing of any product.



The Best Things in Life

Falling in love

Laughing so hard your face hurts

A hot shower

Hearing your favorite song on the radio

Lying in bed listening to the rain outside

Finding the sweater you want is on sale for half price

Chocolate milkshake

A long distance phone call

A good conversation

Laughing at yourself

Midnight phone calls that last for hours

Laughing for absolutely no reason at all

Running into an old friend and realizing that some things (good or bad) never change

Watching the expression on someone's face as he or she opens a much-desired present from you

Waking up and realizing you still have a few hours left to sleep.

Finally waking up to another beautiful day of your life

Siddeshwar Sharma (T.E Etry)

SAE

End of the Year Report of SAE-KJSCE 2006-2007

The club ended its 3rd successful year of existence at the end of the academic year 2006-2007. Under the guidance of Prof. B. M. Pradhan as Faculty Advisor and Prof. S. R. Bhandari as Additional Faculty Advisor, and along with the entire students council lead by Preyank Sheth, Chairperson and Bhaargav Rengarajan and Shubhra Sinha, Vice-Chairpersons, SAE-KJSCE has become one of the leading student chapters of K.J.Somaiya College of Engineering.

The year began with a massive membership drive with SAE's membership count reaching almost 200 in number which included students from all four years of Engineering. To ensure maximum participation and to offer everybody opportunity and convenience, we extended the members' entry upto September. With a major chunk of the members being from mechanical, this year's main objective was to do away with the notion that SAE is a mechanical society. We were successful to a good extent with membership and active participation from electronics, computer science and telecom branches.

The first event of the year, 'The Rock Quiz' was a huge success. It was spread over 4 days from 21st to 24th August with participation of more than 50 students. There were written elimination rounds to qualify the best 8 teams for two semi-finals. After that, was the grand finale with 4 teams competing head-on (no pun intended) for the crown of the "Rock Junky" of SAE. The grand prize was cash prizes plus tickets for Independence Rock 2006.

All fun and games apart, we wanted to learn something so, the quiz was followed by an Industrial Visit to Mahindra Sona Ltd. and Mahindra & Mahindra Ltd., Nashik. The Mahindra Sona plant manufactured drive-shafts and universal joints for automobiles. It was a very informative visit which was

well explained by experienced officers working at the plant. The components and the manufacturing process that we saw complemented the theoretical knowledge we get in college. The visit to the Mahindra Sona Plant was followed by a well prepared full meal at the campus mess. After that we proceeded to the Mahindra & Mahindra Assembly Line of the Scorpio. The plant assembled the petrol and diesel variants of the SUV sold in India as well as the pick-up model and the left-hand drive car for exports to South Africa and the Middle-East. The entire process was explained by trained professionals working at the plant. It was a unique experience to see the entire process of assembling the car, each part fitting in its place perfectly like a jig-saw puzzle. We thank Prof. Bhusnoor for accompanying us and to Abhijeet Anam (S.E.Mech) for organizing the Visit.

After the visit came the very hip, the very happening, Auto-Workshop. It was conducted in a span of 3 days from 27th to 29th September. In only its second edition, the auto-workshop achieved legendary status with cars like a fully souped up Honda City with NOS tanks, turbos - the works; a custom modified Maruti Swift with spinners on the wheels and blinkers on the head lamps. With good music, it looked almost like an underground racing scene. The other cars present included the newly launched Honda Civic from Arya Honda, the Audi A6 from Island Motors, the original rugged Jeep, a custom Ford Ikon, 1942 Vintage BSA Bikes and the Bullet Thunderbird. Each vehicle was accompanied by experienced personnel from the authorized dealers who explained the under-hood mechanisms and overall working of the car in sessions of half hour each. With participation of students as high as 250 the auto-workshop this year set the bench-mark for societies to organize an event as popular as this one. Our special thanks

go to Mr. Ankur Shah for getting his cars (Maruti Swift, Jeep and Honda City) and showing us some of his driving talents as well. A special mention to Niket Gandhi for helping make the Auto-Workshop a success.

After the success of the Auto-Workshop things were quite at the surface with no events organized that calendar year. This was because we were busy planning the biggest event of the year, AutoMechanika 2007. Held on the 16th and 17th of February, the event was thronged by more than 2500 students and other visitors from colleges all over Mumbai. On the 16th was the Go-Karting Championship held at The Acres Club, Chembur. To say that this tournament was a success would be a gross understatement. We had nearly a 100 participants from all across the city taking part in this championship vying for the crown of the speed demon. The sheer success of this event has ensured that this novel enterprise initiated by SAE-KJSCE this year, is bound to become bigger in the coming years.

On 17th February was the main day of AutoMechanika, '07, which included various events such as Car Design, Heptathlon, F.R.I.E.N.D.S. Quiz, Aero-modelling Workshop, Engine Workshop and X-Box Gaming. The crowd puller though was the Auto Expo. With cars like the BMW 503d, Skoda Laura, Honda CR-V (New), and the 1947 Morris gracing the grounds outside the college, the crowds thronged the place in large numbers. We also had participation from the Red Bull Team, who handed out free cans to the thirsty enthusiasts. The total participation of the Auto Expo itself reached to around 1000 persons. Our special thanks to Jeet Mehta (S.E. Mech) for his visionary ideas and his determination to realize them.

The day ended with the Prize Distribution Ceremony. Prof. Thosar

SAHAS

and Prof. Pradhan gave away the prizes to the eager winners of all the competitions thus, bringing to an end a very successful day for the SAE Council and the volunteers who had worked long and hard for the last two months.

Following the grand event was a modest but well prepared event of Technical Paper Presentation (TPP), for which we had participation from two teams which were selected to represent our college for the annual TPP event held by SAE-India. This was the last event of the year 2006-2007. We look forward to having more of you with us in 2007 - 2008.

SAE - KJSCE

Strive, Achieve, Excel



Seasonings

Your mouth produces 1 litre (1.8 pints) of saliva a day.

The length from your wrist to your elbow is the same as the length of your foot.

The muscle that lets your eye blink is the fastest muscle in your body. It allows you to blink 5 times a second. On average, you blink 15 000 times a day. Women blink twice as much as men

Not all our taste buds are on our tongue; about 10% are on the

palette and the cheeks.

Our eyes are always the same size from birth

Traffic lights were used before the advent of the motorcar.

Forks, mostly being two-tined, used to be known as "split spoons."

TIP is the acronym for "To Insure Promptness."

Traffic jams of New York, San Francisco and Paris are well known - beaten only by those in Seattle where a driver annually spends 59 hours stuck in traffic

Basketball and rugby balls are made from synthetic material. Earlier, pigs' bladders were used as rugby balls.

Golf the only sport played on the moon - on 6 February 1971 Alan Shepard hit a golf ball.

$12+3-4+5+67+8+9=100$ and there exists at least one other representation of 100 with 9 digits in the right order and math operations in between

The Council

Chairperson	: Kanva Upadhyay (S.E Mech.)
Secretary	: Aditya Rege (S.E Mech)
Cultural Secretary	: Fenil Savla (S.E Mech)
P.R.O	: Monica (S.E Etrc)
Treasurer	: Vinay Parte (S.E Mech)

A report on the activities of SAHAS for term 2006-07:

I) SAHAS announced the committee in a faculty meeting.

The new committee consisted of the following members:

1. Mrs. Meera Vankatesh : Chairperson
2. Mr. S.R Chawade Mani : Secretary
3. Mr. Santosh Mani : Treasurer
4. Mr. Ravindra Salvi : Jt. Secretary

II) SAHAS celebrated Science Day on 14th March 2007. Prof. S. S Sane, Professor, Dept. of Mathematics, Univ. of Mumbai, delivered a talk on 'Cryptography' which was well attended by the students of all branches. A question-answer session cleared many doubts and queries. Prof. Sane expressed appreciation on the students' participation and enthusiasm.

On this occasion, toppers in Applied Science and Mathematics of Semester-I were also felicitated with certificates for the first and second positions respectively.

III) On 27th April 2007, SAHAS organised an industrial visit for students of First Year to ONGC's, IOET Panvel. 11 students were accompanied by two faculty members, namely Dr. V. R Naik and Prof. Chawade.

Interesting facts

Report on Somaiya Tadmna Vyakhyan Mala Lectures

Over the last one year, K. J. Somaiya college of engineering, Vidyavihar, has started organizing an expert lecture series, Somaiya Tadmna Vyakhyan Mala on the various current topics related to the professional life of engineering students. The college has invited the prominent scholars, academicians, professionals to pool their expertise for the upcoming future challenges in their area.

First (talk) Inaugral talk of Somaiya Tadmna Vyakhyan Mala:

Theme: Indian professional for the the twenty first century.

Resource Person(speaker): Dr. Deepak B. Phatak

Day and date: Saturday, January 21, 2006

Time: 3.15 pm to 4.45 pm

The lecture was conducted by Dr. Deepak B. Phatak, Subrao Nilkani chair professor, Kanwal Rekhil school of information technology, Indian Institute Of Technology Bombay. This inaugural lecture was organized in co-ordination with the Department Of Mechanical Engineering in the presence of a galaxy of dignitaries including Dr. (Mrs) P. P. Parikh, the Director General, Somaiya Tantravihar, Proffesor Bhushan Pradhan and the Heads and the Deans of various departments of the college.

In his talk, Dr. Deepak B. Phatak gave a panaromic view of the emerging IT scenario in the context of new technological trends and complex applications needed in the twentyfirst century. He also mentioned the need of imbibing the important technological skills and leadership qualities to play a leading professional role and face the future challenges in life.

The second lecture was organized in co-ordination with Electronics Engineering students association (EESA) on 'Women Engineers in India' by Padma Shri Dr. Suhas P. Sukhatme, ex-director, Indian Institute of Technology, Bombay.

Dr. Sukhatme gave an overview of his extensive study on the involvement of Indian Women in the engineering profession which he called- the 'Silent Revolution' in the field of technology, focusing on the issues like enrolment and the turn-out of the women engineers, statewise and disciplinewise, job opportunities in the public and the private sectors, job status, nature of work, career profiles and career problems.

Third Talk Of Somaiya Tadmna Vyakhyan Mala

Theme: Environmental concerns of Mumbai

Resource person: Dr. U. C. Mishra

Day and Date: Saturday, February 11, 2006

'Save Aamchi Mumbai' from environmental degradation was the main theme of the third lecture which was on- 'Environmental Concerns of Mumbai' by Dr. U. C. Mishra, Ex-Director, Health, Safety and Environmental Group, Bhabha Atomic Research Centre (BARC). He suggested five 'P's i.e. Population, Poverty, Pollution, Politician and Police responsible for the environmental degradation in Mumbai.

Fourth Talk Of Somaiya Tadmna Vyakhyan Mala

Theme: Information Security for Everyone

Resource person: Shri Nandkumar Sarvade

Day and Date : Saturday, March 11, 2006

Shri Nandkumar Sarvade, Director Of Cyber Security and Compliance, NASSCOM spoke on 'Information Security For Everyone', covering the issues like the use of Information Technology in cyber space, real and virtual world and related risks. He also stressed upon the need for the knowledge of security.

Fifth Talk Of Somaiya Tadmna Vyakhyan Mala

Theme: Exciting times- Challenges and opportunities

Resource person: Dr. Arvind Kudchadkar

Day and Date : Saturday, October 7, 2006

Dr. Arvind Kudchadkar, Educatinal advisor, RELIANCE industries limited and the founder of the Dhirubhai Ambani Institute Of Information Technology, Gandhinagar, Gujarat spoke on -'Exciting Times challenges and opportunities. In his educative talk, he threw light on the impact of I.T revolution and globalization on the world and focused upon the tremendous challenges and opportunities in the field of the I.T industry.

Sixth Talk Of Somaiya Tadmna Vyakhyan Mala

Theme : Design and Development of Embedded Systems

Resource person : Rear Admiral V. Balchandran

Day and Date : Saturday, March 3, 2006

The talk was on Design and Development of Embedded Systems by Rear Admiral V. Balchandran. He mentioned the prominent role of embedded systems coupled with hardware and software in a hi-tech world. In his talk, he focused on the effective development of the embedded systems and strategies for ascertaining the reliability and reactivity of the system.

Seventh Talk Of Somaiya Tadhya Vyakhyan Mala

Theme : 'Tomorrow's IT and business world'- A roadmap to success'

Resource person : Shri Achyut S. Godbole

Day and Date : Saturday, April 7, 2007

Talking about the importance of the awareness of the recent developments in the field of I.T for the professionals, Shri Achyut S. Godbole gave a graphic

picture of the historical development of I.T and business study in his talk on "Tomorrow's I.T And Business World". He focused on its application in the fields of computing, medicine, biotechnology, artificial intelligence, robotics, space and entertainment. He also spoke about the skills and qualities like fundamental technical knowledge, language competency in English, managerial skills and prompt habit of learning and unlearning which are required to be an effective I.T professional in the tomorrow's I.T business.

Seasonings

Claim To Know Your College?

Let's see.. Answer the following questions and see how much you score

- 1) When was KJSCE established?
- 2) Name the Principal of KJSCE.
- 3) How many drawing halls are there in college?
- 4) What does SIMSR stand for?
- 5) How many eating joints are there in the campus? Name them.
- 6) Where is the medical center of our college?
- 7) How many deans are there? Name the Dean of Academic Affairs.
- 8) What is the full form of TVM?
- 9) What is the name of the festival organized by
 - a. EESA
 - b. CSI
- 10) Where is this garden located?
- 11) Where is the television room which serves as the source of live cricket updates?
- 12) What is the acronym of the post 'LR' in the Students' Council?
- 13) What is the acronym of the popularly known CCF?
- 14) Rearrange to get a 'two word' popular food item on the canteen menu: CRNEAAMCHRNIUI
- 15) Which place do the ventilators in the photograph belong to?



Turn to page no: 56 to see your score.

12-15 : A conscious Somayite

8-11 : A decent score

Below 8: If you're not an FE then you don't deserve to be in KJSCE!

Gallery Staff

(Standing L to R)
Prof A S Thosar, Prof B M Pradhan
Vice Principals

Sitting (L to R)
Dr (Mrs) Medha Dixit, Principal
Dr (Mrs) P P Parikh, Director General



Deans of The Institution
L to R
Dr A K Chaudhary, Dean Academics
Prof N R Gilke, Dean, PRO
Dr (Mrs) Medha Dixit, Principal
Prof (Mrs) Arati Phadke, Dean, Student Affairs



Heads of the Departments
(Standing L to R)
Prof S S Thakur, HOD, Electronics & Telecommunication
Prof M S Marathe, HOD, Electronics
Prof N S Chandrashekhar, HOD, Mechanical
Prof Deepak Sharma, HOD, Computers

(Sitting L to R)
Dr (Mrs) Veena Naik, HOD, Science & Humanities
Dr (Mrs) Medha Dixit, Principal
Prof (Mrs) Nandana Prabhu, HOD, Information Technology

(Standing L to R)
Umesh Hiremath, Librarian
Prof Yelpale, Sports In Charge

Sitting (L to R)
Prof Manish Pote, Controller of Examination
Dr (Mrs) Medha Dixit, Principal
Prof U B Joshi, Coordinator, CRPQA





Office Staff (Standing L to R)
Mr Shivale, Mr Ashok Kunder,
Mr Mohandas,
Mr Shetty

Sitting (L to R)
Mrs Menon,
Dr (Mrs) Medha Dixit, Principal
Mrs Rukmini



Union Representative
(Standing L to R)
Mr Talele, Mr Vishwakarma, Mr Dabholkar

(Sitting)
Dr (Mrs) Medha Dixit, Principal



Magazine Committee
(Standing L to R)
Sohit Raina, Sukanya Rajkhowa, Rutvik Sheth

Sitting (L to R)
Prof M S Marathe
Dr (Mrs) Medha Dixit, Principal
Mrs Usha Padmanabhan

Report of the Students' Representative for Alumni Interaction

Riddbi Shah

Special thanks to:

Prof. Arati Phadke;

Dean of student affairs.

Dr. A. K Chowdhary;

Dean of academic affairs.

Mrs. Leena Vyas.

'Alumni' refers to the group of ex-students of any institute that stays connected to the institution in some way or the other over the years. My post, 'Students' representative for alumni interaction' had mostly to do with updating and interacting with our college alumni fraternity with the current happenings of the college. This task seemed quite small but when it involved co-ordinating with about 8000 ex-students, it needed planning and on-time execution.

The idea of keeping the past students bonded with college gave me the incentive to send them 'The Somaiya Newsletter' periodically. The following newsletters were sent to about 1500 to 2000 ex-students from time to time:

1. Introduction of Students' Council 2006-07.
2. Report on annual placement.
3. Marketing brochure of Symphony '07.
4. Post symphony report
5. Invitation for the 'Annual Alumni meet 2007'.

Each of the above newsletters was received very well by our ex-students. Many of them replied with new suggestions, new templates of the newsletter and some actually contributed in the marketing amount for Symphony '07'. I would like to thank each of them to have taken efforts to

appreciate our work. I can't forget to thank Sukanya for designing each newsletter with her creative vocabulary and varied formats.

While updating the alumni website www.kjscealumni.us, I got in touch with Mr. Sameer Modi (staying in U.S.A), who has been an active owner of this website and he helped me a lot in updating it. For this purpose, I received help from Mr. Aviraj Ajeekar and I am very grateful to him.

Unlike the other Students' Council posts, the responsibility of this post never ends. Building a strong network between the college students, ex-students and administration is an ongoing process which will require years of efforts; an effort to bring them together, to keep them together, which requires strong support from all fronts. As a representative of the college students, I tried my best to give in my bit and wish to continue doing the same as alumni too.

Seasonings

How to combine images to make a panoramic picture

By capturing a series of images around a single point of rotation using a tripod, you can scan these images into your computer and stitch these pictures together to make one seamless panoramic picture.

Things You'll Need

- " Camera on a tripod
- " Large landscape or extensive scene you want to photograph
- " Computer with scanner
- " Image editing software
- " Laser printer using photo paper

Steps

1. Begin by setting up your camera as level as you possibly can facing the landscape or large scene you want to



capture.

2. Take your first picture of the far left edge of the scene you are capturing.
3. Rotate your camera to the right so that the frame still overlaps the previous frame on the left by 25%, and take your next picture.
4. Continue to rotate in this fashion and take a picture until you reach the far right side of the scene you are photographing.



5. If you are using a film camera use a scanner to upload your pictures into your computer.
6. Using the panoramic feature on your imaging software of choice, stitch together the pictures where they overlap.
7. Once finished, save the completed panoramic picture and print it out on a laser printer using photo paper.

Then & Now The period 1983-2007

D H Dixit

Alumni
1983-1987

And for 2007, a few stray thoughts, a few general observations and a few points of view (all my own work).

It has been two decades since June 1983, that K J Somaiya College of Engineering and I got together to spend about 42 months (last 6 months at Godrej & Boyce Mfg Co), in each other's company.

Then there were only two colleges with Production Engineering (VJTI & K.J.S.C.E), **now** there would be more than Twenty-Two.....

Then there were only Top Two Colleges in Mumbai for Engineering (VJTI & S.P.C.E), **now** there are about Top Twenty colleges in Mumbai.

Then there were only two + two courses like Mech, Elec, Civil & others available, **now** there are Twenty + Twenty choices like I.T, I.T.E.X, Comp Engg, Bio Eng, and Environment Engg.

Then my dad could afford to shell out Seven Thousand per annum for the course & now I should be ready with one lakh forty thousand.

Then the college was a shared building with the Diploma & Science College, **now** it stands pretty tall like a cake.

Then we all were admitted into the course with marks of 52/750, **now** the cut offs are 675 / 750.

Then there were about 20 staff and 20 books to help us qualify as engineers, **now** there are about 200 staff and 2 lakh books to guide new engineers.

Then we had a loving professor Mrs. Kumthekar and now also she is there supporting the alumni activities.



Then it was a dream that Vidyavihar be renamed Somaiya Vihar, and now also we are still nourishing it.

Then there was a large number of visiting faculty who had only Saturdays and Sundays for engineering sermons (Monday to Friday at VJTI), **now** the visiting faculty is missed, only to be institutionalized into coaching classes.

Then to get an engineering degree you have to fill individual colleges' admission forms (about a month's time was required to rush from Mumbai to Nasik To Loni to Aurangabad to Latur & back), **now** a single form does the trick.

Then the starting salaries were a good Rs.2000/- per month, **now** they are about Rs.20,000/- per month.

Then we all thought about what is in store for our future, **now** we are all happy remembering our old days and years.

Then the examinations were a serious issue now it is a more serious issue.

Then we had launched A.P.E. (Association of Production Engineering Student), **now** it no longer exists, (Darwin's laws have annihilated it).

Then we had a gala time bunking lectures, copying in exams, fist pounding all professors and colleagues **now** the frequency & intensity have gone up.

Then there were no Alumni (1987 out) **now** there is an Alumni Association and about 20 First Batches attended in 2005.

Then we were waiting with full enthusiasm to embrace the future, open our wings and fly, show the world what we are, dreamt to be different, and **now** proud to say that we are the first batches of K.J.S.C.E. and Hip Hip hurraay to all for braving and finishing 24 years of memories, stored, cherished, refurbished and ever continuing.

Networking - A Bright Career Option

Sandesh Jadhav

B.E. [EXTC-2003 Batch]

(Currently working in JET AIRWAYS as Telecommunication Engineer)

All of you now must be on the verge of taking the great leap into "the market". Everyone does face a dilemma of whether to go for MBA, M.Tech, MS etc. or at the most join any software company as a fresher. Let me take you to one of the most upcoming & bright career option called ITeS (IT-Enabled Services). It has withstood the test of the worst slowdown since the inception of IT industry in this country. In a year of layoffs and benching, it has generated employment at a faster rate than any other employment, and in times of slow growth rates and slack revenues, it has registered its strongest growth ever.

There are various sub-fields engrossed under the broader term "ITeS". One of them is called Computer Communication & Networking. It includes installation of IT & Telecom infrastructure for any kind of organization, may it be banking domain, BPO, Call centre, Aviation industry or Railways reservation system. I mean you name the domain & you will find this technology there.

Rather than explaining this subject in more technical terms I would like to make this article a simple & more informative one.

In our day to day life we withdraw money from ATM, but have you ever given a thought on how this ATM machine transaction takes place? For e.g. I am holding an account of any XYZ bank, in their branch at Ghatkopar, how can I withdraw money from my account anywhere in the world? Or if I am calling any toll free number for any kind of product support in any part of the world, just by keying in series of numbers through my phone, how come my call lands up on exact desk where my query gets solved.

How can I book tickets, for my journey from Delhi-Calcutta by sitting in Mumbai?

The answer to all these questions is Computer Communication & Networking which is a part of a very upcoming & booming sector called ITeS.

Let me elucidate this with the help of a small network diagram given below, we will take example of one global bank named XYZ how they exactly works:



these centrally located servers. If this information has to be carried over to overseas then V.S.N.L comes into picture, i.e. International Telephone

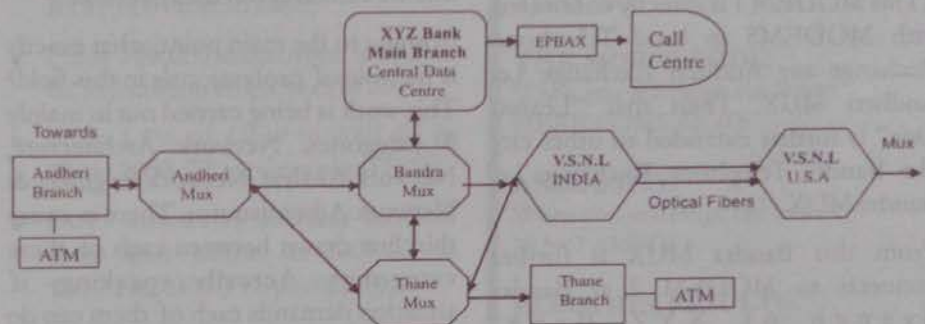

As you can see in this diagram, I am holding an account with XYZ Bank in their Andheri branch, when I am depositing money in my account at Andheri, this information is carried from Bank to local Mux [Multiplexer] which is situated in Local Telephone exchange. From there it goes to intended telephone exchanges. All these exchanges are interconnected with each other with optical fibers. From this local Telephone exchange, say in Thane i.e. Thane Mux to Thane branch of the same bank. Thus I can withdraw my money from Thane branch ATM. My account information can be found in centrally located servers of the bank. In this case the main branch is at Bandra. All information of all account holders in Mumbai & nearby cities is stored in

exchange intended for transmitting data out of our country. This V.S.N.L exchange has been connected with help of optical fibers which are laid under the ocean. These under sea fibers are reaching up to various countries till their V.S.N.L end i.e. their International Telecomm Exchange and then connected to their local telephone exchanges. Similar process flow is followed at both the ends.

The devices which are included in this type of transmission are SWITCHES, ROUTERS & MODEMS. The role of Network Engineers is to configure these devices. The devices are being manufactured mostly by giant companies like CISCO & Nortel they are no 8 & no 14 in fortune 500 respectively.

The series of devices which have to be implemented are shown in diagram below

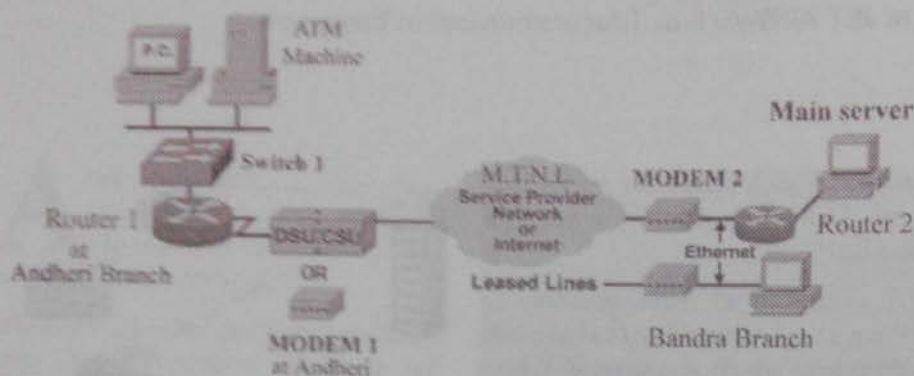

B.S.N.L. They are available in bandwidth from 64 kbps upto 45 Mbps. When we want to take our data internationally, these lines are called as

From the above network diagram you will come to know how exactly flow of data takes place. The PCs of XYZ bank at Andheri branch are connected to SWITCH 1 to ROUTER 1 then to DSU/CSU i.e. Leased Line MODEM 1. This MODEM 1 is directly connected with MODEMS in local Telephone Exchange say Andheri Exchange i.e. Andheri MUX. Then that "Leased Line" is further extended to other city like Bandra Telephone Exchange i.e. Bandra MUX.

From this Bandra MUX it further connects to MODEM 2 at Bandra branch of XYZ Bank. From Modem 2 to Router 2 Switch 2 PC's & ATM machines & Servers of Bandra branch

This concept is applied all over the world for connecting one to one or one to many sites whether they are Intra-city, Inter-city or international. Now the role of networking professionals is to configure or program these series of devices i.e. Switches, Routers & Modems. It's not hard core programming or coding but it is only giving instructions to these devices, what they should do when particular type of traffic comes to them in their respective syntax.

The connecting lines which I have shown in this diagram are called as "Leased Line". As the name suggests we are taking them on lease from service providers like M.T.N.L. or

IPLC (International Private Leased Circuit). These are actually optical fibers which are laid off under sea. Big Telecomm giants like MCI, SPRINT or our Indian companies like TATA, Reliance give us these lines on lease so that we can carry our data overseas.

Coming to the main point, what exactly is the role of professionals in this field? This work is being carried out in mainly 4 categories. Network Architecture, Network Analyst, Network Engineer & Network Administrator. There is a very thin line drawn between each of these categories. Actually speaking, if situation demands each of them can do each other's job. These categories have been specified only on the basis of specialized portfolios which are handled by them.

Like the name suggests Network Architecture designs, plan of his entire network from one end point to other end point. Then network analyst calculates the number of devices required in it & of what caliber devices are required. Like in Desktops we are having categories P III, P IV depending on their speed, performance. Same kind of concept is being applied here. Like there are Routers & Switches with higher speed, superior performance which are required to be installed for carrying heavy data traffic and that to instantly.

Network engineers do actual configurations of these devices &

install them. In addition to this category there are Network Security engineers who are taking care of devices like firewall to secure their network, since he is transferring company's data publicly & no one can intervene their information flow.

After implementing the network continuous changes are happening in network like no. of users increases/decreases new site has been added to the network. Some changes have to be done continuously in firewalls. We have to even keep the network 24 X 7 up & running fine so that no end users can get affected. This job is carried out by network administrators.

Some times when you visit your bank they might respond to you, sorry as none of the transaction will take place as all our systems are down. You might be wondering when their PC's are working, on what basis they are claiming that their systems are down. It only means that, one of the devices like Router, Switch or Modem in chain which I have explained in second diagram is not working properly. So here the role of network engineer is to identify the problem & resolve it immediately. It's really a very high caliber job where you have to work under huge pressure keeping your mind cool. If you feed in, one wrong command in the router at this end in India then your entire network at other end in USA can come down. All the data & information flow of one company before going out aggregates at one place in the data centre & from there it goes out of the network of a company or a web. The network engineer is the one who handles a very confidential data of the company. Thus, besides being at extremely sensitive job, the engineers are paid high for keeping the trustworthiness and loyalty towards their organization.

Another upcoming technology you might have heard is "VoIP [Voice over IP]". One more sizzling profile I would like to discuss here called as "Voice Engineer"

All this communication flow which I have explained above, takes place over the IP i.e. Internet Protocol, the unique number [IP ADDRESS] which is assigned to your PC. By reference to this number your PC talks to the network or to the internet cloud.

So "VoIP" is the technology where in your voice is being carried out on these IP packets for e.g. your Google or Yahoo voice chat. The same concept is being applied in Call Centers, BPO or all big organizations, who wants to cut their telephone bill prices almost by 100%, by carrying voice communication over the VoIP phones.

Once these "Leased Lines" & IT infrastructure has been laid out across the countries, you can make as many no of calls from those countries at the local cost. This is the concept of the Toll-free number. That is the reason why this Call Centre industries, BPO, KPO has been set up in India. After implementing the network infrastructure, what they need is only fluent English speaking manpower which they get at almost 70% less price.

The devices which are used to convert this IP packets into voice are called as EPBAX [Electronic Private Branch Automatic Exchange] Companies like Avaya, Nortel, Panasonic, and Alcatel are giants in this field.

You might have experienced when you call any help line or toll free number. They will ask you to dial [1] for English [2] for Hindi, then again press [3] for credit card info, press [9] for operator's assistance etc. How after pressing series of keys from our phone, our call lands up on the desk & our query gets solved?

This is possible because of configuration of these telecom products called EPBAX. Even these devices are needed to be configured, which is done by Voice Engineers. Again computer networking & voice engineering go hand in hand because these devices are being connected to the SWITCHES or Leased Line MODEMS which I have explained above. Telecom Engineers should really

concentrate on this as a career option.

Lot of Diploma holders & non-technical back ground students are entering into this field, just because of lack of awareness in our BE students. Pay wise if you compare these people with software engineers, you might find it low initially but it is low only initially. Afterwards software professional with 2 yrs of experience & networking or voice engineers with same no. of years of experience, you will certainly find that the package of Networking Professionals is superior. Rather than praising more about this ITeS sector just go through facts & figures from NASSCOM.

- Growth rate of 73% in 2001-02, against 14% for the overall IT industry;
- From Rs 7,100 crore in 2001-02 to Rs 81,000 crore in 2008;
- From 106,000 employees in March 02 to 2 million employees in 2008;
- From 1.4% of GDP in 2001-02 to 7% in 2008 (IT services plus ITeS);
- Forex inflows to increase ten-fold from \$6.2 billion in 2001-02 to \$60.72 in 2008 (ITS plus ITeS);
- The largest player, General Electric, to increase employee count to Rs. 20,000 by 2005; and
- Customer care, HR and payment services will constitute 70% of long-term ITeS potential.
- NASSCOM has 210 registered ITeS companies
- 50 global companies to offshore ITeS services to India
- ITeS is expected to account for 37% of the country's software and services export segment by 2008

The bottom line is everybody has a choice and area of interest of their own; one should not run behind money or brand sacrificing his/her own area of interest. This article is just to make you aware of the various opportunities & growth in this field which most of us are

still ignorant about. Just analyze your own interest and the prospects; not just the career growth in a particular field but how fast that growth is also matters. Best of Luck, for your bright future!!!

Seasonings

Play with words

DORMITORY:

When you rearrange the letters:
DIRTY ROOM

ASTRONOMER:

When you rearrange the letters:
MOON STARER

THE EYES:

When you rearrange the letters:
THEY SEE

THE MORSE CODE:

When you rearrange the letters:
HERE COME DOTS

ANIMOSITY:

When you rearrange the letters:
IS NO AMITY

ELECTION RESULTS:

When you rearrange the letters:
LIES - LET'S RECOUNT

MOTHER-IN-LAW:

When you rearrange the letters:
WOMAN HITLER

A DECIMAL POINT:

When you rearrange the letters:
IM A DOT IN PLACE

THE EARTHQUAKES:

When you rearrange the letters:
THAT QUEER SHAKE

AND FOR THE GRAND FINALE:

ELEVEN PLUS TWO:

When you rearrange the letters:
TWELVE PLUS ONE

Bhavesh Jain

T.E. Etc

From The Horses' Mouths

Aniket Mitra
S.E. Etrx

All of us here in KJSCE aspire to do well in life. Some want to go for further studies in our existing fields, some want to gain work experience while others dream of getting into a renowned B-school. I have spoken to a few seniors from our college and have tried to get your common queries answered. I hope you will find the information useful.

Harshad Pande

B.E. (Etrx) Batch 2003

Currently working in Patni Computer Systems

1. Which book should we use to prepare for placements? Read R. S. Aggarwal (Quantitative) thoroughly
2. Are certifications required? They are not very important
3. What does the industry expect from a fresher? Industry expects a very good aptitude
4. What subjects are important from your field for the interview? Digital and applied electronics, C, C++
5. What are your future plans? I took the GRE but my score wasn't too good. So I will continue with my job and see how things shape up.
6. What is considered as a good GRE score? Above 1300
7. Is there any use of taking GRE while working? After job experience, you are in a better position to decide in what field you would like to pursue your higher studies.

Vikas .R

B.E.(Comps) Batch 2005

Currently working in Accenture

1. Tell me something about your

interviews and job experience? Industry provides various technical applications, ERP training etc

2. What subjects are important to clear the interview? Data structures, Java
3. What does the industry expect from a fresher? A good aptitude for learning and ability to apply techniques practically
4. What are your plans? I am planning to take CAT
5. What is the best time to take CAT? During final year
6. What is a good score? 98 percentile
7. How long should the preparation be? At least 8 months of serious preparations

Abhijit N. Chavan

B.E. (Mech), Batch 2005

Currently working in Mahindra & Mahindra

1. What does the industry expect from a fresher? Basics should be strong e.g. Reading drawings etc. A good technical knowledge and excellent aptitude
2. How should one prepare for an interview? Revise subjects such as Fluid Mechanics, know what the company is into, what is its market link, the technical aspects it is dealing with. Have good knowledge about the company's projects
3. Anything else that might be helpful for job interviews? Being a part of an organization or a council like the Students' Council may be helpful
4. Are certifications required? Participation in technical paper presentation, robotics, important workshops might be helpful



Rajiv Nair

B.E. (I.T) Batch 2005

Currently studying in IIM-A

1. When is the best time to take CAT? Many people might suggest that a competitive exam like CAT should be given during a job to gain experience and make that count. However, I feel there is no use wasting time in a technical job when you might end up in a different field of management. Best time is in the final year.
2. What is a good score? Not below 90 percentile
3. Is CAT really that tough? No, in fact it is not; the questions are not that hard to crack; depends on how well prepared you are. It's the competition which is rigorous
4. What is the formula of your success? There is no formula. It depends on how motivated you are to do well.

Balaji Iyer

B.E.(Etrx) Batch 2007

Currently studying in Syracuse University, USA

1. What is your GRE score? 1490
2. How long did you prepare? 3 months

- 3. Where did you study from? Barron's, Big Book, CDs
- 4. When do you think is the best time to take it? March of the Sixth Semester, that way you get time to prepare and still have time left over for semester VI preparation
- 5. What kind of a GRE score is safe? 1100+ for safe schools, 1250-1300+ for the good schools. However, you must make sure you meet the required cut-offs for the analytical writing section, also the quantitative section.

- 6. What aggregate is considered good? Depends on the university you are applying to, but a good aggregate obviously helps. Some universities don't attach too much importance to the aggregate, some do. What matters is the grade point average, or GPA. Better the GPA, better your chances of getting into a good university
- 7. On what basis did you choose the universities? There are several aspects of choosing the university. The main focus must be on the subject you are

planning to do. Each university has a different area of research and make sure you take a look at those areas while you apply. That apart, influencing factors include cost, availability of funding, on-campus jobs, etc.

- 8. What about the assistantships & aids? Assistantships and Aid are available if your profile looks good. that includes a good GRE score, and a high GPA.. which means a high aggregate. Challenging projects undertaken by you are a plus.



Unbelievable Things Happen In America...

- 1°) Fold a \$20 bill in half...
- 2°) Fold again, taking care to fold it exactly as below
- 3°) Fold the other end, exactly as before Et voilà, the PENTAGON on fire!!
- 4°) Now, simply turn it over... The Twin Towers ablaze....

COINCIDENCE? YOU DECIDE

As if that wasn't enough... here is what you've seen...

Firstly The Pentagon on fire...
Then The Twin Towers...

... and now... look at this!

TRIPLE COINCIDENCE ON A SIMPLE \$20 BILL



What a coincidence!



A simple geometric fold creates a catastrophic premonition printed on all \$20 bills!!!



As if that wasn't enough... here is what you've seen...



Rajendra K. Varma
B.E.-Computer Engg.

ORION RACING: TO GERMANY AND BACK

FSG 2007 is Formula Student Germany ; an international Design and Engineering Competition held at Hockenheim, Germany in August 2007. FSG is one of the many international competitions of the FSAE series of competitions. The event is officially sponsored by leading corporates like Audi VW, BMW, ThyssenKrupp, Mahle, Brunel, Dekra, Solid Works, Continental, Bosch and TUV. The main aim of the event is to build a formula style-racing car, which is then judged on various static and dynamic events. The car has to be built by undergraduate students abiding by the SAE rule book. The objective of taking part in this race is to develop a team of industry-ready engineers - since this competition tests not only our engineering skills, but also develops our ability to meet deadlines, to present, to budget, to manage teams and to market our product. More details about the competition can be found at www.formulastudent.de.

Team Orion comprises of students studying Mechanical and Electronics engineering at K. J. Somaiya College of Engineering. They participated in FSG 2007. The 1st year's team comprised of around 30 members and the new team consists of around 35 members. The Team is divided into a number of sub systems namely Chassis, Steering, Suspension, Brakes, Engine, Drivetrain, Bodywork & Aerodynamics, Air intake and Exhaust and last but not the least Electronics. The Electronics team incorporates new and high end electronics onto to the car; to name a few there are projects such as Data-Acquisition, Telemetry, Fuzzy Logic controlled Semi- active suspension, custom built, programmed and tuned Electronic Control Unit and not to mention the entire car wiring.

The team also comprises of non technical teams in the form of Marketing, Logistics and Public

Relations. Most of the team members have taken up different sub-systems of the car as their final year projects.

Team Orion already built a low budget prototype car named the B-150 i.e The Barracuda 150 for first hand experience and publicity cum sponsorship purposes. It was powered by a 145cc Bajaj autorickshaw. The B150 received nationwide publicity through leading newspapers and news channels on its completion and unveiling last year. The car in striking red was so impressive as a student run project that the auto giant Honda Siel India Ltd. was impressed and they sponsored a huge sum of our entire project budget

The second car built by Team Orion, a black beauty, was a high budget single seater racing monster named the B-600 i.e The Barracuda 600 for the competition purpose. This mean machine was powered by a 599cc Honda CBR 600 F4i Engine. The car boasts of many critical parts being imported like the differential; shock absorbers, wheels and the custom programmable ECU Megasquirt.

The B600 too like the B150 received nationwide publicity through leading newspapers and news channels on its completion and unveiling on the 20th July 2007. The car then was air-freighted to Frankfurt Germany and on its route to Hockenheim for the event while the team members left for Frankfurt on the 31st July. Team Orion also collaborated with co-participants KA- Racing of University of Karlsruhe, Germany.

This year's 12 member team which went to Germany was as follows:

Tojo Thomas	T.E.Mech
Chiraag Thakkar	T.E.Mech
Abhijit Desai	B.E.Mech
Amit Chopra	B.E.Mech
Hiren.Patel	S.E.Mech
Apurav Jain	T.E.Etrx



Sharukh Vazifdar	B.E.Mech
Shubra Sinha	B.E.Mech
Satvik Batavia	B.E.Mech
Meeral Shetia	B.E.Mech
Sujay Kawale	B.E.Mech
Siddharth Sirigeri	B.E.Etrx

The participation in the competition was a huge, out of the world learning experience. The ultra-strong foreign teams were in a league of their own compared to our first year team dominating all sub events of the competition but that did not stop Orion Racing from putting K J Somaiya College of Engineering and India on the world map.

Team Orion will continue participating in the prestigious competition FSG in the years to come and the tradition and experience will be passed on, to the next year's teams forming a legacy of improving the overall quality of engineers coming out of the gates of K. J. Somaiya College Of Engineering

RACE ON.....!

Tojo Thomas

B.E.MECH

For further information, log onto www.orionracing.com.

Space Elevator-The Highway to Heaven

Report By:

Navin Kamath (*Te Comps*)

Tejas Pai (*Te Comps*)

Manoj Nachimuthu (*Te Comps*)

2nd prize CSI Tech paper

Space Elevator-The highway to heaven

From the day man was born the vastness of space has amazed him and continues to do so till this day. With every passing day our brain has evolved to think faster and better and with this has evolved our curiosity of space. Today in the 21st century we dream of colonizing moon and other planets in our solar system. We dream of discovering life on some other planet who will be our first companions in this vast universe. The present technology does not seem sufficient to achieve this dream. The tremendous costs (**each rocket launch costs half a billion dollars**) and the risks involved in presently used rocket propulsion technology have urged scientists to come up with more economical and reliable technology. Rockets once launched cannot be reused. This can be achieved in future using **SPACE ELEVATOR**.

What is a space elevator?

A space elevator is essentially a long cable extending from our planet's surface into space substantially beyond geosynchronous orbit (100,000 km altitude). The competing forces of gravity at the lower end, and outward centripetal acceleration at the farther end, keep the ribbon under tension and stationary over a single position on Earth. This ribbon, once deployed, can be ascended by mechanical means to Earth orbit.

Mechanism

Base Station: The space elevator will

originate from a base station on earth which will be either mobile or stationary located in the equatorial plane of earth.

Mobile stations are typically large ocean going vessels whereas stationary platforms can be located in high altitude location such as on high towers. Mobile platforms have the advantage of being able to maneuver to avoid high winds, storms, and space debris while stationary platforms don't have this; they typically have access to cheaper and more reliable power sources

Cable: The most critical element of the elevator will be the cable composed of the carbon nanotubes which is not only light in weight but also has tensile which will be sufficient to build an elevator. Another important point in cable design is the variations in the width of the cable along its length. The width of the cable at any point depends on the strength of the cable at that point.

Counter-weight: At the top of the cable there will be a very heavy counter-weight which will keep the cable taut. There have been two dominant methods proposed for dealing with the counterweight need: a heavy object, such as a captured asteroid, positioned past geosynchronous orbit, or extending the cable itself well past geosynchronous orbit. The latter idea has gained more support in recent years due to the relative simplicity of the task and the fact that a payload that went to the end of the counterweight-cable



would acquire considerable velocity relative to the Earth, allowing it to be launched into interplanetary space.

Climber: The climber will use the cable to guide its ascent to space. The climber would use pair of rollers, moving arms containing pads of hooks, magnetic levitation etc. to hold the cable with suitable friction. The same concept can be used for down-climbers. Once operational, climbers could be climbing the space elevator nearly every day. The climbers will vary in size from 5 tons, at first, to 20 tons. The 20-ton lifter will be able to carry as much as 13 tons of payloads and have 900 cubic meters of space. Climbers would carry cargo ranging from satellites to solar-powered panels and eventually humans up the ribbon at a speed of about 118 miles per hour (190 km/hour).

Power beaming: One of the technological challenges of building and using a space elevator is getting enough power to a climber such that it can travel from Earth to geosynchronous orbit in a reasonable amount of time. From strictly an energy standpoint climber will need 49 MJ/kg of mechanical energy to ascend from Earth to geosynchronous orbit. If we consider one week travel time and 1000 kg climber as a baseline will require 80

kW, plus losses, average power to the climber and result in a preferred power density of roughly 2kW/kg for the power system onboard the climber.

Hence the climbers will be powered by a **free-electron laser system** located on or near the anchor station. The laser will beam 2.4 megawatts of energy to photovoltaic cells, made of **Gallium Arsenide (GaAs)** attached to the lifter, which will then convert that energy to electricity to be used by conventional, niobium-magnet DC electric motors.

Working

Stage1: The initial requirement for space elevator is setting up a base station. The base station will act as an anchor which holds the cables to the earth. The base station will be positioned on the equator.

Stage2: Once the base station is setup, then a rocket would launch a special satellite into space that would position itself in a geostationary orbit exactly over the platform. This means that the satellite would remain over the platform for its entire deployment.

Stage3: A conventional rocket would carry a spool of the ribbon to an orbit some 35,000 km above Earth's surface. The scientists have chosen this orbit

because it keeps the elevator above the same point on Earth as the planet rotates. Otherwise, the elevator ribbon would drift east or west relative to a fixed point on Earth, and tension on the ribbon would vary.

Stage4: Once this main cable has been sent it is strengthened by some more assisting cables just as a backup in case of damage due to asteroids or wear and tear.

Stage5: Now our next aim is to send the climber up the cable. We would be using laser power beaming which is most suitable for this purpose. A laser on the anchor platform focuses beams at GaAs cells attached to the bottom of the climbers to provide power to their DC motors. The climber would use pair of rollers, moving arms containing pads of hooks, magnetic levitation etc. to hold the cable with suitable friction. The same concept can be used for down-climbers.

Stage6: The horizontal speed of each part of cable increases with attitude, proportional to distance from the centre of the earth and on reaching orbital velocity at geosynchronous orbit. Therefore as a payload is lifted up a space elevator it gains altitude as well as angular momentum (horizontal

speed) necessary to set spacecraft in orbital motion around earth.

Advantages and Applications

- 1) Cost will be less comparatively than the present technologies like the rockets and geostationary satellites cost billions for one time use only.
 - 2) The Space Elevator will be capable of placing into various orbits, including LEO and GEO and beyond, large payloads such as very long open booms, huge radio dishes, complex planetary probes, and manned modules including hotels and penal colonies.
 - 3) Spacecrafts could be constructed more cheaply since delicate components will not need to be protected against launch shocks.
 - 4) One major use envisioned at outset is to harness the limitless energy of the sun and beam it down to Earth a constant source of clean, renewable power. This would have enormous implications for the environment and sustainable development by cutting fossil fuel consumption and eliminating harmful Greenhouse gases.
- This technology which was ridiculed years back is now capable of changing the very meaning of "space travel".



That's called teamwork!! The 250 plus Infra volunteers!!



FOSS & Engineering

Sameer Niphadkar

BE - Comps

also published at the Goterber Univ essay competition, Sweden

Why should engineering students use FOSS? After all, the curriculum does not adhere to it. Besides how does it matter if we (engineering students) do not learn or use FOSS? Some of us may be familiar with the term of 'open source' and some may have even worked with 'linux'. (Oh yeah! that was in the first year right?) And after that...the most common reactions are "It's too hard" or "Its not yet ready" or "User-friendliness is a major problem" or "The file system unfamiliar".

Whatever be the reason some way or the other, most of us find an excuse for not extending our relationship with linux and for that matter even with other open source softwares. So what's the point bothering about FOSS now??

Well...just read along. In this brief article I'd like to clear certain misconceptions about open source software. Who am I do to that? I am just an average PC user who has managed to get hold of this FOSS idea. I would also like to stress its importance in our education and practical applications. First let us start with some 'Do you know facts' Do you know that:

- * About 90% of the DNS (Domain name servers) run on Bind an open source software
- * About 65% of the Web servers run on Apache (an OSS)
- * Around 45% of the Email transactions happen on Sendmail and its variants (Qmail etc..) again OSS
- * The world's 3rd fastest supercomputer runs on GNU (FOSS) - Thunder California Digital 2005
- * You can yourself comfortably create a grid based supercomputer with speed upto 1 MIFS again using FOSS - Flash

mob computing

* Most of the open source software is freely downloadable of the Internet and can be legally copied and distributed among the users, unlike proprietary software which requires licensing of each copy on every PC.

* FOSS is the most secured software in the world and NSA (National Security Agency) uses and recommends it for security - SELinux

* FOSS development in whole can be considered to be atleast 10 times larger than any software company with over a million people contributing in some way.

* Over 100 million people, including you! use FOSS in some way

* World's leading software companies like IBM, HP, Oracle, Sun, Apple, Novell etc are now backing FOSS

* FOSS does not mean only GPL Some of the most talented people in the world are

* FOSS developers, FOSS has been existent for over 20 years now.

Get the picture?

Open source software is like a duck which appears to be calm on the surface but paddles with great strength underwater. But now how does it benefit you? (Again the same question) Well...from my experience, I would recommend you to give it a try. Do try and install (for installation and partitioning/dual booting - do refer the web or ask the pro people for help) some of the popular flavors of the GNU/Linux operating system. Mainly Fedora Core, Open SUSE and Ubuntu. You may either download these distros or ask for it from those who have them. (Just to let you know...we have now a

whole stock of these and other distros in the college, ask the Computer Department or CSI people for details). Then try and experiment with all the open source softwares, the list of OSS and their proprietary counterparts is given below.

Finally as you become accustomed to linux, join a LUG of your area or city (for us in Mumbai its India Linux User Group Bombay ILUG-B). Here you would find all the experts and open source evangelists ready to help you with any of your practical problems in FOSS. And believe me for us engineering students learning comes best when we are practically using and toying with a software. ILUG-B undergoes transactions via the mailing list and conducts its monthly meet somewhere in an educational institute in the city - mostly at IITB.

Here you may learn about the latest development in FOSS. Once you acquaint yourself with OSS and know about its working, its time to see what's under the hood...yes the source code. Initially observe and try to understand the source code of smaller programs. Here learn the concept of software development. This is very important as ultimately in the future you would be actually working somewhere and what matters then is your practical knowledge. (Mainly applicable to CS and IT students) The best way is to read the documentations and try to run the code on your machine. Secondly, try to configure all your external devices (sound-graphics card, usb ports, window's disks, printers, scanners, webcams, flash mp3-players etc) for linux. I know its hard work but once you do it all the things related to management would be quite clear. Then if you have the interest make your own shell scripts or

scripts using your favourite scripting language to run cron jobs.

Try to configure your machine as a Web, Email, DNS, firewall and proxy server...if you arrive upto this level you can consider yourself almost as a free software pro.

Now if you genuinely have the liking then try to give back something to the FOSS community. Try to be a part of the various communities of FOSS - linux, apache, php, gnome, kde, mozilla, fedora, suse, open office, debain...the list goes on. As you can see, FOSS would ultimately help you to gain knowledge and whatever be your interest (Web services, Operating Systems, DBMS, Networking, Embedded Systems, System Administration. Again applicable to CS and IT students)) FOSS can be your first step towards that direction. Its just as RMS (Richard Stallman - GNU founder) would say "Get into the code to manage it better". And who knows one day, millions of people may be using your coded software just like we are now using Linux, Apache, KDE etc. Finally I'd like to say that FOSS would educate you with the application of computer science and would evolve you as a true engineer.



Did you know that

1. A day on Mars is about half an hour longer than a day on Earth?
2. A rollercoaster has no engine?
3. One in every four Americans Has appeared on Television?
4. Uganda has the source of River Nile?
5. It takes around 10 litres of milk to make 1kg of cheese?
6. More people get killed by dogs than by sharks?

Application Of RFID In Education Replacing Barcodes by RFID Tags for Paper Identification

By: Jain Apurav

1st Prize EESA Presentation

What is RFID?

RFID Systems consist of a transponder, also known as a tag, which is basically a microchip connected to an antenna. The tag is mounted to an item, such as a pallet of goods in a warehouse, and a device called a reader communicates with the tag via radio waves. Depending on the type of tag that is used, the reader can receive detailed information or it can receive data as simple as an identification number.

RFID is similar to barcode systems in which data, such as a price, is accessed when the barcode is read. The main difference is that the barcode must come in direct contact to an optical scanner/reader and the RFID tag can transmit to the reader via radio waves and does not have to be in direct contact. An RFID reader can receive data from as many as 1,000 tags per second.

RFID products use low, high, ultra-high and microwave frequencies to store, send, and retrieve data about monitored products or devices. There are several types of RFID products. Tags or transponders are microchips that attach to RFID antennas and receive signals from and transmit signals to RFID readers. Each RFID tag contains a unique serial number and, in some cases, information such as a customer's account number and location. RFID readers use radio waves to communicate with tags and send information in digital form to computerized systems. RFID antennas are conductive elements that enable tags to send and receive data.

Transceivers are RFID products that can both send and receive information. Special RFID printers are used to encode RFID tags. Complete RFID systems include tags, readers, and printers.

RFID products use three basic technologies: active, passive, and semi-passive. Active RFID tags use a battery to power the microchip's circuitry and transmit signals to readers. Typical active tags can be read from distances of 100 ft. or more. Passive RFID tags do not include a battery. Instead, they derive power from a magnetic field that is formed by the coupling of the reader's antenna from a tag with the reader's antenna from a reader. Semi-passive tags are similar to active tags in that they use a battery to run the microchip's circuitry; however, they do not communicate with RFID readers. To conserve battery life, some semi-passive tags remain in a "sleep" mode until contacted by a reader.

A passive (paper) RFID tag:



Passive RFID tags have no internal power supply. The minute electrical current induced in the antenna by the incoming radio frequency signal provides just enough power for the CMOS integrated circuit (IC) in the tag to power up and transmit a response. Most passive tags signal by backscattering the carrier signal from the reader. This means that the aerial (antenna) has to be designed to both collect powers from the incoming signal and also to transmit the outbound backscatter signal. The response of a passive RFID tag is not just an ID number, the tag chip can contain nonvolatile EEPROM for storing data.

How Our RFID System works

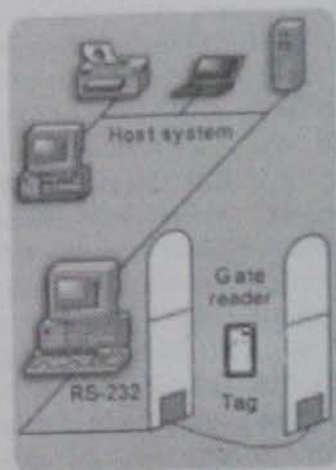

- RFID tag gets into reading device's electromagnetic field.
- Tag receives the signal which energizes the passive tag
- tag transmits the data stored in the IC in return
- reader passes the information to the host system

Our system:

- We propose to replace the currently used barcodes on the papers by RFID tags. The tags will be inserted in the papers itself. There will be a reader installed at the gate of the correction cell. The papers are taken inside the correction cell in a bunch. So when a paper is carried into the room it is detected by reader and then registered in the system. So the system has an idea how many and which papers are inside the room.

When an attempt is made to take the paper outside the cell the reader detects the subsequent tag. As soon as the reader detects the tag it triggers the alarm system. Hence any attempt to take the paper out of the cell is foiled.

Expansion of current system:

- Our system can be expanded by replacing the passive tags with active tags. As passive tags can be also be used to larger data the marks of the students with the roll numbers can be fed into the tag. When the marks are to be fed into the system of a university same can be read directly from the reader from the tags and hence eradicating any chance of malpractice while feeding of the marks is done which is done manually under the current system. Hence the whole system of correction of papers would be devoid of any malpractice.



"Wannabe Engineer types"

Only 2 types of wannabe engineers exist in this god forsaken engineering college..

The 1st types will always be seen on the "SLOPE"
No matter at which angle the hour hand of your wrist watch points to....
The other types are at some local "TAPRI"
Smoking the usual duplicate cheap branded cigarette
And don't forget to FLAUNT it with "STYLE"

The 1st types always order plenty in canteen
And make sure they declare a treat
On the left over noodles

The 2nd type take turns over months to order one ½ rice plate
But do make sure that.....that 1 plate has 6 extra spoons
And call it "friendship"

The 1st types don't dare to look straight into the eyes of the pretty girl at college
And call it "ATTITUDE"
While the other types get dehydrated
Looking at her

The 1st types are always late for their lectures
And when asked about the reason for being late by 40 minutes
Every single human on this planet has just 1 answer
"TRAINS were late ma'am"
The other types reach early by 15 minutes
But forget to leave the CCF and the lovely ORKUT early
And so end up saying.....
"TRAINS were late ma'am"

The 1st types get beaten up by the external professor in "VIVAS"
The other types....don't dare to appear

The 1st types are finally granted a degree.....
to allow peace and humanity in the college
and then they are forced to join a call center
But don't forget to mention that..... "This is what I always wanted to do...!!!"
While the 2nd types still keep appearing for the Mechanics....BEE.....CP-1,2,3.....n
where "n" is a positive integer
and keep preaching the "valuable information" mentioned above with the F.E's that keep coming year after year
but don't forget to mention that.....
"this is anytime better than a call center"
And GOD only knows whether they ever leave the college...

Nimish Tanna
T.E.I.T

OFDM-FLASH

Shah Pratik Vijay
B.E. EXTC

Introduction.

Digital multimedia applications as they are getting common lately create an ever increasing demand for broad band communication systems. Although the technical requirements for related products are very high the solutions must be cheap to implement since we are basically talking about consumer products.

Whereas for the satellite channel and for the cable channel such cost-efficient solutions already exist for the terrestrial link (i.e. classical TV broadcasting) the requirements are so high that the 'standard' solutions are no longer feasible or lead to sub optimal results. Orthogonal Frequency Division Multiplexing (OFDM) is a method that allows to transmit high data rates over extremely hostile channels at a comparable low complexity.

Orthogonal Frequency Division Multiplexing (OFDM) is a Multi-Carrier Modulation technique in which a single high rate data-stream is divided into multiple low rate data-streams and are modulated using sub-carriers which are orthogonal to each other. Some of the main advantages of OFDM are its multi-path delay spread tolerance and efficient spectral usage by allowing overlapping in the frequency domain. Also one other significant advantage is that the modulation and demodulation can be done using IFFT and FFT operations, which are computationally efficient. In-fact, Code Division Multiple Access (CDMA) technique used in 2nd and 3rd Generation Wireless Networks may give way to combined OFDM and CDMA technique called Multi-Carrier CDMA (MC-CDMA).

FLASH-OFDM is a next generation

mobile broadband system. The first generation was analog, the second was digital, and now Flarion is introducing a packet-switched, all-IP system. "FLASH" is used to signify the fast hopping that is done across all tones in a pseudorandom predetermined pattern (Fast, Low-latency Access with Seamless Handoff). This fast hopping makes FLASH-OFDM a spread spectrum technology, meaning that data is packetized and spread out over a wider range of spectrum, enabling a larger number of transmissions and more secure delivery. With fast hopping, a user that is assigned one tone does not transmit on the same tone every symbol, but uses a hopping pattern to jump to a different tone every symbol duration. Different base stations use different hopping patterns, and each uses the entire available spectrum (frequency reuse of 1). In a cellular deployment, this leads to all the advantages of CDMA systems, including frequency diversity and out of cell (intercell) interference averaging — a spectral efficiency benefit that narrow band systems like conventional TDMA cannot realize.

In contrast, CDMA users in a sector do interfere with each other, increasing the total interference in the system, with the result that FLASH-OFDM has up to 66% less physical layer interference than CDMA. FLASH-OFDM therefore has the physical layer benefits of both CDMA and TDMA and is up to three more times more spectrally efficient than CDMA. In other words, at the physical layer, FLASH-OFDM creates the fattest pipe of all cellular technologies. Even though the 3x advantage at the physical layer is a huge advantage, the most significant advantage of FLASH-OFDM for data is at the Media Access Control (MAC) and link layers.

OFDM for Mobile Communications

OFDM represents a different design approach. It can be thought of as a combination of modulation and multiple access schemes that segment a communications channel in such a way that many users can share it. When TDMA segments according to time and CDMA segments according to spreading codes, OFDM segments according to frequency. It is a technique that divides the spectrum into a number of equally spaced tones, and carries a portion of a user's information on each tone. A tone can be thought of as a frequency, much in the same way that each key on a piano represents a unique frequency. OFDM can be viewed as a form of frequency division multiplexing (FDM). However, OFDM has an important special property: each tone is orthogonal with every other tone. FDM typically requires there to be frequency guard bands between the frequencies so that they do not interfere with each other. OFDM allows the spectrum of each tone to overlap, and since they are orthogonal they do not interfere with each other. By allowing the tones to overlap, the overall amount of spectrum required is reduced.

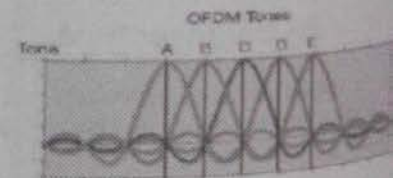

OFDM is a modulation technique that it enables user data to be modulated onto the tones. The information is modulated onto a tone by adjusting the tone's phase, amplitude, or both. In its most basic form, a tone may be present or disabled to indicate a one or zero bit of information, however, either Phase

Shift Keying (PSK), or Quadrature Amplitude Modulation (QAM) is typically employed. An OFDM system takes a data stream and splits it into N parallel data streams, each at a rate 1/N of the original rate. Each stream is then mapped to a tone at a unique frequency and combined together using the inverse Fast Fourier Transform (IFFT) to yield the time domain waveform to be transmitted. For example, if a 100 tone system were used, a single data stream with a rate of 1 Mbps would be converted into 100 streams of 10 kbps. By creating slower parallel data streams, the bandwidth of the modulation symbol is effectively decreased by a factor of 100, or equivalently, the duration of the modulation symbol is increased by a factor of 100. Proper

selection of system parameters, such as number of tones and tone spacing, can greatly reduce, or even eliminate, ISI since typical multipath delay spread represents a much smaller proportion of the lengthened symbol time. Viewed another way, the coherence bandwidth of the channel can be much smaller since the symbol bandwidth has been reduced. The need for complex multi-tap time domain equalizers can be eliminated.

OFDM can be combined with frequency hopping to create a spread spectrum system, realizing the benefits of frequency diversity and interference averaging previously described for CDMA. In a frequency hopping spread spectrum system, each user's set of tones is changed after each time period (usually corresponding to a modulation symbol). By switching frequencies after each symbol time, the losses due to frequency selective fading are minimized. Although frequency hopping and CDMA are different forms of spread spectrum, they achieve comparable performance in a multipath fading environment and provide similar interference-averaging benefits.

Therefore, OFDM combines the best attributes of TDMA, in that users are orthogonal to one another, and CDMA, as discussed above, while avoiding the limitations of each, including the need

for TDMA\frequency planning and equalization, and multiple access interference (in the case of CDMA).

Two-dimensional illustration of OFDM Channel Resource

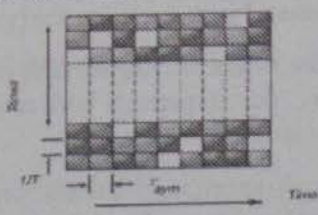

OFDM Design Considerations

A number of design tradeoffs must be considered when developing an OFDM-based system. These decisions will be governed by the way the system is intended to be used, including the degree of mobility, the data rates required, the services to be supported, the number of users to be supported, and the environment the system will be used in. The most fundamental tradeoff is the basic sub carrier, or tone characteristics, which involves selection of the number of tones, the bandwidth of each tone, and the cyclic prefix duration.

The cyclic prefix, which is a system overhead, prefix must be long enough to account for the anticipated multipath delay spread experienced by the system. For a given symbol duration the amount of overhead increases as the cyclic prefix gets longer. Delay spreads encountered in cellular systems are typically less than 10 microseconds.

interface technology designed for wide area networks in licensed spectrum. However, unlike its predecessors, the FLASH-OFDM system is pure-IP and packet-switched, delivering broadband data and voice to a greater number of mobile users. The emerging success of the FLASH-OFDM mobile communications network can be attributed to its highspeed downlink and uplink, and low latency performance replicating a wired broadband experience. But how does it work?

Based on Orthogonal Frequency Division Multiplexing (OFDM), FLASH-OFDM segments a wireless communications channel (spectrum) so that many users can share it. Segmenting according to frequency (tones), rather than time or codes (TDMA and CDMA respectively), FLASH-OFDM uses fast hopping across those tones to create a highly secure and high capacity Physical Layer (wireless pipe). This Physical Layer is vertically integrated with innovative control layers (MAC and Link Layers) to create a fast, reliable, and efficient process of moving data and voice packets wirelessly. Finally, the FLASH OFDM Network Layer utilizes an all-IP and packet switched infrastructure to route those packets in a cellular environment. The concept of FLASH-OFDM was initiated had concluded that because third generation (3G) mobile networks relied on voice-centric

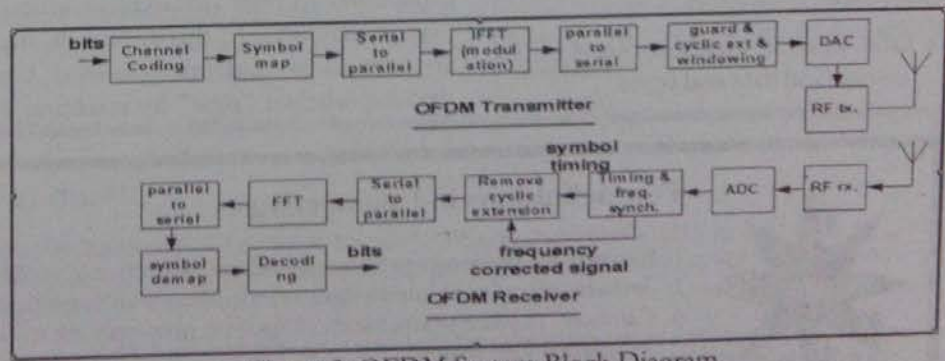

Figure 3: OFDM System Block Diagram.

The Mobile Broadband Communication generation.

Like its predecessors, TDMA and CDMA, FLASH-OFDM® is an air

(circuit-switched) architectures, they would not be able to scale to the demands of broadband data transport. Created to combine the attributes of both CDMA and TDMA technologies,

while avoiding the limitations of each, FLASH-OFDM began to alter the cellular landscape with its LAN-like performance and full mobility for broadband communication.

The FLASH-OFDM system

The FLASH-OFDM system enables a mobile operator to deploy an all-IP, nationwide system that profitably delivers true value to the subscriber (Enterprise or mass market consumer):

- All-IP and packet-switched: no changes to protocol, settings, devices and content required
- Mass-market pricing - flat rate broadband at consumer price points
- Quality of Service (QoS) for priority access, tiered pricing and revenue maximization
- Highest spectral efficiency of any mobile broadband system commercially available (only 1.25

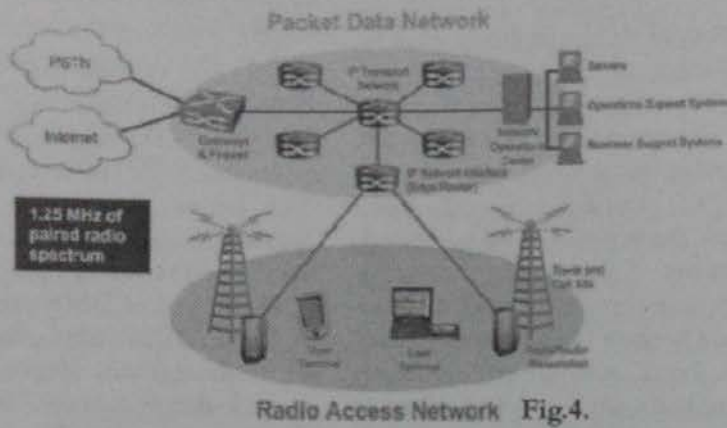

- Broadband access - typical user data rates of 1.5 Mbps, with latency (network delay) as low as 35ms
- Ubiquity of cellular - a vehicular mobility experience
- Mass-market pricing - flat rate broadband at consumer price points
- No changes to existing computing devices or applications

The following value to the mobile operator:

- One wireless wide area network for broadband data and voice

MHz paired FDD spectrum needed for a nationwide network)

- Enterprise-class security
- W A N - W i r e l e s s L A N interoperability (ubiquitous access) with WiFi
- Seamless cell-to-cell handoff

2.5 and 3G cellular solutions, on the other hand, incrementally add data capabilities to their hierarchical, voice-centric networks. In this approach, the application is re-defined around the existing wireless "pipe" by rewriting /

thinning down the content and associated interactive applications, such as voice over-IP (VoIP). This not only limits user experience to a mere fraction of what's possible on the Internet but also comes at a hefty price premium because the immense content, applications infrastructure of the Internet are leveraged, but reinvented.

A critical aspect of the network is Radio-Routers (combination of routers and wireless base stations) autonomous.

A further benefit of autonomy is each Radio-Router is *backhaul agnostic*. Each Radio-Router can attach to any domain using any desired backhaul technology: T1, Gigabit Ethernet, ATM, and others.

Significantly Reduced Capex and Lifecycle Costs

- RadioRouter base station delivers low cost of bandwidth on a mobile network
- Pure IP for low cost integration with an existing core network
- Able to use existing antennas towers
- Minimizes Radio Access Network (RAN) provisioning, facilitates centralized management, includes extensive diagnostics

References:

- 1 Bell Laboratories (NJ, USA) and Flarion's Founder and CEO, Dr. Rajiv Laroia. Dr. Laroia
- 2 IEEE Paper, MAC Ltd. Site, Dec 450 site.



Few definitions in Engineering..:

1. Education: Teaching a person to be literate so that he can spell his name on unemployment forms.
2. Seniors: 'claim' to be knowledgeable individuals with tons of advice which they themselves do not follow.
3. Canteen: A place where meals are gulped, proposals are made, study strategies are discussed and where assignments are written.
4. Viva: An interaction between a highly knowledgeable individual and an ignorant fool who pretends to be knowledgeable.
5. FE's: The new bakras who are made to work during festival days.

Milesh Nima
(T.E. Comp)

Bluetooth V/s Wibree

Ajinkya Tirpude
T.E. EXTC

Third Prize EESA Presentation

Nokia launched low rate, low power, small size, low cost cable replacement radio technology.

In October 06, Nokia announced the existence of yet another wireless technology named Wibree developed by Nokia's researchers.

Wibree's properties can be summarized as follows:

- It works on the ISM band, already shared by Wi-Fi, Bluetooth, ZigBee and other proprietary technologies.
- It has a 30-foot (10-meter) range, similar with Class 3 Bluetooth.
- It can achieve speeds of up to 1 Mbps.

By looking at its properties, Wibree is somewhat the earlier Bluetooth version but Nokia argued that Wibree is different because Wibree achieves its performance with one tenth the power consumption of Bluetooth and smaller footprint. Wibree addresses a niche that hasn't been addressed by other wireless technologies.

Technology-wise, nothing new and special about Wibree, since several proprietary short-range radio

technologies also work with very low power such as the potential Kleeer but Nokia aims to push Wibree to becoming an open standard by taking advantage of Nokia's leading position in mobile phone business. Nokia encourages other companies to license Wibree, creating a Wibree ecosystem emulating the success of Wi-Fi and Bluetooth, and developing standalone Wibree chip and dual-mode Wibree-Bluetooth chip.

In a standalone scenario, Wibree is going to be embedded in devices which require very long battery life therefore need to be recharged infrequently, such as watches, health monitors, sport sensors, keyboards, mice, and toys. However as a number one mobile phone maker, Nokia doesn't hide its ambition to integrate Wibree into its mobile phones by creating a dual-mode scenario that's Wibree on Bluetooth chip. The dual-mode Wibree-Bluetooth chip is targeted for mobile/portable devices such as mobile phone, PDA, notebook.

The typical applications Nokia uses as examples automatically direct my mind to ZigBee (low rate WPAN IEEE

802.15.4). ZigBee is promoted by several industry leaders in sensor, monitoring and automation business. Its specification had already been completed and certification has been started. Whilst Bluetooth has throughput advantage over Wibree, ZigBee has range advantage over Wibree. Moreover, ZigBee has networking capability. Wibree is caught in the middle.

But the fact that ZigBee is still far from replacing the X10 protocol and the likes for one of its target markets, i.e. home automation might have led Nokia to develop yet another radio technology and put Wibree on a distance from ZigBee. In my opinion, ZigBee players lack the drive to push ZigBee to the mainstream and ZigBee doesn't have a news-machine. No one did like what Intel had done for WiMedia-UWB (WUSB) and WiMAX.

Below is a comparison table examining the feasibility of Wibree for today's common applications and the foreseeable future with a mobile phone as the base device. Please note though that a Wibree Specification hasn't been released so this is only a general assessment.

Seasonings

Animal's love for music

Cows actually produces more milk if they listen to music. They're quite picky though, only relaxing music will work particularly Beethoven's Pastoral Symphony and Simon & Garfunkel's Bridge over troubled water.

Researchers found cattle that were exposed to slow music for 12 hours a day, from 5am to 5pm, over the course of nine weeks. Each cow's milk yield rose by 3% (0.73 liters or 1.54 pints) a day when slow music was played.

Some farmers already play music to chickens, as there is anecdotal evidence that it reduces stress.

If you're not into slow-mo music, you might want to take up a lesson or two from them because termites would chew through wood twice their usual speed if Rock music is played!



Application	Wibree	Bluetooth	ZigBee
<i>Business card or other PIM data exchange</i>	Yes. The size is small, only text file.	Yes. Its primordial use.	No. Not designed for this.
<i>Transferring small item like image, song (ringtone), short clip one at a time</i>	Yes	Yes. Already in use.	No
<i>Wireless headset or handsfree kit</i>	No. Audio is not in its profiles, although theoretically it can be done.	Yes. Has upgraded it to support stereo audio.	No
<i>Synch'ing mobile phone with PC</i>	No. Too slow especially for Synch'ing many items.	Yes. One of its popular applications.	No
<i>Using mobile phone as a dial-up modem</i>	No. Not within its targeted application.	Yes. Has been used by travelers.	No
<i>Image, photo, or video/audio clip folder transfer/sharing</i>	No. Will be very slow.	Yes. Still needs speed increase as multimedia files become larger	No
<i>Human Interface Device (HID): keyboard and mouse</i>	Yes. One of its main targets. Need to switch current Bluetooth based products to Wibree.	Yes. Already in use and available from many vendors.	Yes. But implementation is almost unheard.
<i>Wireless printing</i>	Yes. One of its main targets. But over time its speed would keep users away from it.	Yes. Already in use. The next generation Bluetooth (WUSB-alike) has greater potential.	No
<i>Remote controlling TV, lamp, window, door, AC, etc</i>	Yes. One of its main targets although its reach has to be optimized. Interesting if a cell phone becomes a universal remote control.	No. It theoretically can do it but implementation on this field is rare, many proprietary protocols have accomplished the job.	Yes. ZigBee was designed from the beginning for home automation. It has longer reach than Wibree (30 meters or more).
<i>Communicating with wearable things (watch, sport sensor, jewelry)</i>	Yes. One of its main targets.	No. Consumes too much power and has larger size.	Yes. Has advantage in its ultra low power consumption.



Words of Wisdom :

Life is not esoteric at all. It is written on each leaf of each tree, on each pebble on the seashore; it is contained in each ray of the sun - whatever you come across is life in all its beauty.

Optimization of Interest Rates

In Investment Instrument Trading Business

Abstract

Rajapriya Sambandam

T.E. Comps

1st prize CSI Tech Paper

1. INTRODUCTION

The Indian Government bond market comprises securities issued by the Government of India and the State Governments. The term structure of interest rates – the relationship between interest rates in the economy and the term to maturity – forms the basis of valuation of all such fixed income instruments. Modeled as a series of cash flows due at different points of time in the future, the underlying price of any fixed income instrument can be expressed as a sum of the present values of the cash flows.

Consider a fixed income instrument in the bond market. Then, by applying a simple compound interest formula, the forward rate of the instrument is calculated as:

$$FV_n = PV (1+r)^n \quad \text{-----(1)}$$

To calculate the current value of the instrument, given the amount that will be received at maturity, equation (1) is rewritten as follows:

$$PV = FV_n / (1+r)^n \quad \text{-----(2)}$$

where $1/(1+r)^n$ is called the discounting factor.

If the spot rates of interests for every maturity period are known, then the present value of an m-period bond making a series of coupon payments C every period with redemption value R is:

$$PV = (C / (1+r)) + (C / (1+r)^2) + \dots + ((C+R) / (1+r)^n) \quad \text{-----(3)}$$

When these cash flows occur more than once annually we apply the formula for intra-year compounding. The annual rate is divided by n where n is number of time periods to obtain the intra-year compounding interest rate.

Thus,

$$PV = FV / (1 + (r/n))^{nt}$$

As $n \rightarrow \infty$

$$\lim_{n \rightarrow \infty} 1 / (1 + r/n)^{nt} = \exp(-r \cdot t)$$

therefore the discount function $d = \exp(-r \cdot m/100)$ where m is the maturity.

Using the above value of the discounting factor, the interest rate and hence the present value of the instrument can be calculated. It is however observed that the calculated present value of the trading instrument and the actual market price vary.

The difference between these two values may be expressed as below

$$P_{mkt} = P_{est} + e_1 \quad \text{-----(4)}$$

Where e_1 is the error.

The estimated price is:

$$P_{est} = \sum_{j=1}^k d_j(m,b) * c_j \quad \text{-----(5)}$$

Where $d_j(m,b)$ is the discount function calculated as $d(m,b) = \exp(-r(m,b) \cdot m/100)$ -----(6)

Now, the interest rate $r(m,b)$ is a function of four variables $\beta_0, \beta_1, \beta_2$ and τ .

$$r(m,b) = \beta_0 + (\beta_1 + \beta_2) * [1 - \exp(-m/\tau)] / (m/\tau) - \beta_2 * \exp(-m/\tau)$$

where m = maturity

$$b = [\beta_0, \beta_1, \beta_2, \tau]$$

2. PROBLEM DEFINITION

It is our intention to reduce the error in equation (4) by optimizing the interest rate $r(m,b)$ which is the only variable in equation (6).

In order to calculate the optimum value of the interest rate, we need to optimize $b[\beta_0, \beta_1, \beta_2, \tau]$. Various optimization methods may be used for this purpose.

However to solve this problem, the **GENETIC ALGORITHM** is proposed.

3. SOLUTION (ALGORITHM)

1. Start
2. For every trading instrument, generate a random population of n chromosomes $[\beta_0, \beta_1, \beta_2, \tau]$ using value encoding.
3. Set the value of p i.e. the least permissible error.
4. Repeat steps 5 and 6 for all n chromosomes in the population.
5. Repeat for every instrument
 - 5.1 Obtain values of m (maturity), C (Coupon payment amount), T (length of investment) and market price from the spread sheet.
 - 5.2 Evaluate $r(m, b)$.

5.3 Using above value of r , evaluate value for the instrument.

5.4 Subtract the calculated value from market price to obtain the error.

6. Evaluate sum of squared price errors (function). i.e.

$$e = \sqrt{((MP_1 - PV_1)^2 + (MP_2 - PV_2)^2 + \dots)}$$

7. Assign rank to the chromosomes and population.

8. Create new population: Execute following until new population is complete.

8.1 Select parent 1 and parent 2.

8.2 Cross over parents to form off spring.

8.3 With a mutation probability mutate spring.

8.4 Place new off springs in the new population.

9. Test e with rank n i.e. the chromosomes highest fitness. Is $error \leq p$.

If yes stop and return value of chromosome. Else goto step 4.

10. Using the values obtained calculate r for trading instrument. This is the required rate.

11. Stop.



the tank.

World war II tank found in good condition

On Sept 14, 2000, a world war II-era Soviet T-34 tank was pulled out from lake near Johvi, Estonia. The tank had been resting at the bottom of the lake for five decades.

Thanks to a local boy, who, on one day, was walking near the lake and noticed tank tracks leading into the lake. He also saw air bubbles emerging from the lake thus believing that there must be a tank underneath. He told the story to the leader of the local war history club, and later on they arranged for an expedition to look for

Surprisingly, the tank is in good condition. With no rust and all systems in working condition, the tank started with only minor maintenance.

Tele-Immersion - Beyond Videoconferencing

Data accumulated by -
Karthik.Srinivasan

S.E. EXTC

In the office of the future, you won't call people with a phone. You will command your computer to call a particular person. "Computer, call Joe at the London office." Suddenly, one of your office walls will flicker and Joe will be sitting across from you as if he were right there. On the other end, Joe will experience the same immersive connection. That's the idea behind tele-immersion: bringing two or more distant people together in a single, simulated office setting. Business travel will be practically unnecessary.

This type of communication will take us beyond the limits of videoconferencing. Have you ever used a Webcam to teleconference with another person? If you have, then you've seen that videoconferencing via the Internet is not a perfect form of communication. The image is close to real-time, but there are delays that cause a jerking video. Also, if someone walks out of view of that one camera, you can no longer see the person. With tele-immersion, people can't walk out of the view of the camera. In fact, you can peer around their office just by looking at the display screen from different angles. It's like having a window to look through.

Holographic environments will be generated by computers with computing speeds thousands of times faster than your PC. There are several steps to constructing a holographic environment:

1. The computer recognizes the presence and movements of people and objects.
2. The computer tracks those images.
3. The computer projects those images on a stereo-immersive surface.

Tele-immersion may sound similar to virtual reality, but there are key differences between the two

technologies. Virtual reality allows you to move in a computer-generated 3-D environment, but tele-immersion, for now, can only create a 3-D environment that you can see -- you can't interact in it. The next step is to merge tele-immersion and virtual reality to allow users to alter the scenes that they see.

The applications for immersive holographic environments are endless. Imagine a video game free of joysticks, in which you become a participant in the game, fighting monsters or scoring touchdowns. Instead of traveling hundreds of miles to visit your relatives for the holidays, you'll simply call them up and join them in a shared holographic room. Eventually, you will even be able to hug other people using this technology. Doctors and soldiers could use tele-immersion to train in a simulated environment.

Building a Holographic Environment

The early prototypes of tele-immersive displays require users to wear special goggles and a head device that tracks the viewpoints of users looking at the screen. On the other end, the people that appear as 3-D images are being tracked with an array of seven ordinary video cameras, while two other video cameras capture real light patterns projected in each room to calculate distances. This enables the proper depth to be re-created on the screen. So, if a viewer moves his head to the right, he can see the corresponding images that would be seen if he were actually in the room with the person on the screen.

Images on the screen are split and polarized to create a different image for each eye. The goggles then combine these images so that the brain recognizes only one 3-D image. This process is similar to how those old 3-D movie glasses work. The scenes being

projected are only refreshed three times per second, which creates a jerky image. If that rate could be improved to 10 frames per second, it would create a seamless projected image that would be like looking through a window at another person. Scientists are developing new technologies to support this type of communication, including:

- **Internet 2** - This would replace the current Internet infrastructure. This new network will have a higher bandwidth and speeds 1,000 times faster than today's Internet. This high-bandwidth, high-speed network is necessary to transfer the large amounts of data that tele-immersion will produce.

- **Display technologies** - Stereo-immersive displays would have to present a clear view of the scenes being transmitted.

- **Haptic sensors** would allow people to touch projections as if they were real.

- **Desktop supercomputers** would perform the trillions of calculations needed to create a holographic environment. Another possibility to support these environments would be a network of computers that share power.

Tele-immersion will blur the lines between real and computer-generated images. It will be the ultimate tele-commuting technology, almost entirely eliminating the rush-hour drive to work. Instead of commuting, people could attend board meetings by projecting themselves into the company's conference room. And if your job requires you to travel, you could still be home for dinner by tele-immersing yourself into the family kitchen. Because this technology is still in the early stages of development, the possibilities are truly endless.

Our Picture of the Universe

Rutvik Sheth
S.E.(Etrx)

Most of us know about our Universe as a massive space (or void) filled with hundreds of millions of galaxies each of which themselves contain billions of stars and their orbiting systems and other bodies. Among these galaxies a galaxy called Milky Way contains our solar system on the inner edge of one of its spiraling arms which in turn contains our Sun and our planet Earth. But beyond this questions like "Where did the Universe come from?" "What happened before the Universe was formed?" "What is the nature of time?"

And will it ever come to an end? Recent breakthroughs in physics made possible in part by fantastic new technologies have suggested some answers to some of these longstanding questions.

Our first discovery that the Earth was a sphere probably came through Aristotle in 340 B.C from his observations of the eclipses, the heavenly systems and from the fact that Greek ships viewed at the horizon were always seen sail first then the hull. (Although I feel that the ancient Indians had longstanding knowledge on this issue). But he wrongly concluded that it was the Earth that was stationary and the Universe moved around it.

However in 1514 a Polish priest called Copernicus circulated a theory that it was the Sun that was stationary and the Earth and the other planets that revolved around it. His idea was supported by Galileo who had invented the telescope and confirmed the Copernican theory but added that the planets moved in elliptical orbits rather than concentric circles. In 1687 Newton published his work *Philosophiæ Naturalis Principia Mathematica* and in it he postulated a law of universal gravitation according to which every single body in the Universe attracts every other body by a force that is

directly proportional to the distance between them. However this theory raised a important question "Whether the Universe is infinite or is it finite?" because if every body attracted every other body then eventually the entire Universe should fall in to itself at the center point. But if the Universe is infinite then there can be no center point and therefore every star will be surrounded by infinite no of stars attracting it equally in all directions. However it was later found that the finite model was found to be accurate. Throughout this time no one had suggested that the Universe might be expanding or contracting and this reflects the attitude of the people of that time in believing in the eternal truth of God.

Now we come to the question of what could have caused the beginning of the Universe as believed by a no of faiths and religions for without the starting point there can be no hand of their respective Gods in the making. The arguments were if the Universe had a beginning what was present before the Universe began ("What did God do before he created the Universe") and if the Universe indeed had no beginning then that would mean there would be an infinite period of time b4 any event took place which was equally absurd. But in 1929 Edwin Hubble made the landmark observation that wherever you see, you see galaxies moving away from each other which would mean that the objects at one point of time must be closer to each other and at a single point at exactly the same time. This led to the Big Bang Theory where the Universe was infinitesimally small and dense and therefore at this point all laws of science and time would break down and any events predating this event would not effect our current time. This can be considered as the beginning of time

though there is a difference here the previous theories as if the universe is expanding there may be some reasons that it may have a beginning

A physical theory is always proved i.e it is only a hypothesis. No matter how many times an experiment supports a theory you need one contradictory result to prove it wrong. A good theory is one that makes a prediction that could be proved by observations that could be proved by experimentation. Many times new theories are an extension of older theories and thus the eventual goal of science would be to bring out a single theory that describes the whole Universe. It is very difficult to describe the Universe at one go we tend to break the problem up into bits and pieces and then invent a no partial theories that we learn in our education. Each of these theories explains different observations neglecting the effects of other quantities. Today scientists describe the Universe in terms of basically 2 theories - the general theory of relativity and quantum theory. The former describes the force of gravity and the workings of the Universe on large scale while the latter deals with extremely small scales. The major quest of science is now to find a unified theory incorporating both theories even though they have been found to be inconsistent with each other.

THE HISTORY OF PLASMA DISPLAY PANELS

Shah Pratik Vijay

B.E. EXTC

By Jamie Hutchinson

"For most of its time, it was a solution looking for a problem," says Larry Weber (BSEE '69, MSEE '71, PhD '75) of the technology he has dedicated his professional life to. Today that "solution"-the amazing plasma display panel, invented at the University of Illinois in 1964-seems to have finally found the problem (not to mention the goldmine) it always deserved: carrying high-definition television (HDTV) into millions of homes.

Weber's 60-inch plasma display, a prototype he developed for Matsushita (bearing the Panasonic label), combines the large size and superb resolution necessary for HDTV with the convenience of thinness. You can even hang it on your wall. In fact, one of these marvels hangs on the wall of Weber's upstate New York company, Plasmaco, an R & D arm of Matsushita. When you see it, you'll know why the Society for Information Display gave Weber its highest award in 2000 for his contributions to plasma displays.

And you'll begin to understand why the TV industry gave a 2002 Emmy award for technological achievement to the original U of I inventors of the plasma display: Weber's old teachers Donald Bitzer (BSEE '55, MSEE '56, PhD '60) and the late Gene Slottow (PhD '64), and their first graduate student, Robert Willson (PhD '66), whose name appears alongside those of Bitzer and Slottow on the original plasma display patent. Fujitsu, the leading manufacturer of plasma displays, also shared the award.

Now it is just starting to blossom," said Larry Weber of the consumer market for plasma display panels. (Will Faller Photography)

Weber, Fujitsu, and others are now clearing the final hurdle that separates plasma displays from long-term commercial viability: cost. With low-end models selling for about \$3000-half the price of two years ago-manufacturers seem well on their way toward making plasma displays the ultimate solution to the problem of HDTV.

And yet, Bitzer and Slottow had a completely different problem in mind when they created the early displays at Illinois. For them, the plasma display was part of the solution to the problem of computer-based education. What's more, U.S. TV companies who early considered plasma as an alternative to the cathode ray tube soon dropped the idea. A few computer companies stuck with plasma until another flat-panel technology, liquid crystal, seized that market. Other than that, only military contracts sustained a small plasma display industry in the U.S., and so most U of I students who worked on the technology (including Willson) eventually had to find jobs in other areas. Meanwhile Japanese engineers, whose companies dispatched them for extended visits to Bitzer's lab, went home to an electronics industry that today dominates the development and manufacture of plasma displays.

What happened to the flat screen from the flatlands?

The History of Plasma Displays

II. Blue and Orange Beginnings

By Jamie Hutchinson

By 1963 Bitzer had demonstrated the success of his now-legendary automated teaching system, PLATO, within the limited, controlled environment of the Coordinated Science Laboratory. Bitzer and CSL

director Daniel Alpert understood that putting PLATO in practice for large numbers of students-in essence, transforming it from a classroom into a system-would require more than replacing the ILLIAC I, a relic from the days of "big iron" that served as the original mainframe for PLATO's time-sharing network. A real-world PLATO would also eventually require a better way of visually mediating the exchange between computer and student.

At that time, almost all devices for interacting visually with computers were alphanumeric displays that could only render letters and numbers, not the graphics required for teaching and learning many subjects. Bitzer rigged a system using radar display tubes that could digitally read pictures and alphanumeric characters from ILLIAC I, then transmit the images by cable to TV terminals at each student station.

The earliest versions of PLATO used TV sets for the student terminals. ILLIAC digitally sent graphical and alphanumeric data to Raytheon double-electron-gun storage tubes, which were designed to display radar signals and transmit the displayed images. One electron gun would write the data from ILLIAC to the storage tube display, while the other rescanned that display in TV format for cable transmission to the student's TV terminal (shown above). Slides could also be scanned and added to the TV output. (D. L. Bitzer)

The system worked well enough while PLATO was in a proof-of-concept phase. However, the constant refreshing of the image that is required in a cathode ray tube, while fine for TV, didn't lend itself well to the sustained display required for graphics. The tubes had no memory for holding an image, and the cheap computer memory that makes tubes suitable for graphics today was a dear resource in the 1960s.

PLATO would require a better display for the long haul.

Bitzer enlisted Willson, then a graduate assistant, and Slottow, then a research engineer, in the task of exploring how a matrix of discrete neon cells might be driven by a high-frequency ac current, using capacitors at each cell so that individual cells, or pixels, could be addressed. The big breakthrough came one summer evening as Bitzer and Slottow waited outside CSL for their wives to pick them up after work. They began discussing the project in terms of its barest essentials and realized that the simplest configuration would be to exploit the natural capacitance of the glass on either side of a panel, which could be done by placing electrodes on the outside of each cell, separating the driving current from the gas.

Next morning, the team set about building a new device. With Willson doing most of the handiwork, they ultrasonically drilled a hole fifteen thousandths of an inch wide into a thin glass slide, then sandwiched that slide between two others. They deposited thin-film gold electrodes on the outside surfaces to carry a high-voltage driving source. They sealed the sandwich with epoxy on three sides and glued it to a vacuum pump on the fourth, then pumped it clean and backfilled it with neon.

Power on. Blue.

It was July 1964, and the first ac plasma display panel had been built. The panel's single cell operated on the fundamental rules that govern the millions of cells in one of today's panels.

A 4 x 4 pixel plasma display. Graduate student Brij Arora (MSEE '68, PhD '72) built the first multipixel display. "We could address the lines to write the character or erase it. It was a very exciting thing," recalled Arora. (D. L. Bitzer)

After this initial success, the team learned that nitrogen from the air had

leaked into their cell, accounting not only for its blue hue, but also for its good "memory margin"—its property of remaining lit in the presence of a "sustain" voltage significantly lower than the "breakdown" voltage necessary to initiate the discharge. By 1967, the inventors had figured out how to achieve good memory margin using just neon, and they had developed the driving circuitry necessary to address a large array of pixels. (Alpert had kept Bitzer's research under his wing after becoming graduate college dean in the mid-1960s. After the move, Bitzer's lab was renamed the Computer-based Education Research Laboratory.) That year, they built a 16 x 16 panel that glowed orange, thanks to the purer neon mixture. PLATO screens and other plasma panels for years to come, here at the U of I and beyond, would radiate the same orange.

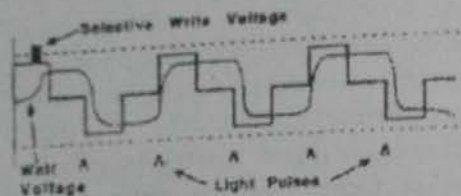

A 16 x 16 pixel "UI" display from 1967. (D. L. Bitzer)

In its "on" state, a plasma cell actually flickers thousands of times per second. Every time the ac sustain voltage reverses polarity, its corresponding field within the cell realigns with an alternating "wall voltage" emanating from the glass, creating a total cell voltage sufficient to ignite the discharge. A new wall voltage of opposite polarity then begins to build up until it cancels the cell voltage, extinguishing the discharge, and a new cycle begins.

The History of Plasma Displays

III. Seeing green

By Jamie Hutchinson

Patent attorney Nate Scarpelli (BSEE '58) was new to the Chicago law firm of Merriam Marshall Shapiro Klose when the firm assigned him the task of

patenting PLATO, the plasma and other ideas for the U of I. "Merriam" was Charles Merriam, sat on the board of the Merriam Foundation and was the driving force behind University Patents, one of the largest patent agencies set up within the Foundation to manage U of I patents, but later spun off as a publicly held University Patents company. The push was on to commercialize U of I technologies—a controversial course for the state land grant institution—toward building the endowment.

Although the first patent covering the fundamental operation and application of the plasma display panel was not granted until 1971 ("one of the most complete applications I think I've ever done," recalls Scarpelli), U of I was collecting on the technology as early as 1967. That year U of I sold an exclusive license to the Owens-Illinois company, which would deliver a commercial-grade "Digivue" display for use in PLATO in 1971. An Owens-Illinois "Digivue" display with electronics exposed (Owens-Illinois)

IBM took an early interest in the lure of Big Blue's prestige as some ticklish negotiations between two corporate players, with the result that U of I collected a few dollars from IBM in exchange for another license. That license was in 1983 to the IBM 3290 Initiator Panel, "the industry's first large-screen plasma terminal for commercial use," according to an IBM advertisement. TV companies including RCA and General Electric took an early press reports about plasma displays as potential "hang-on" products. Some took out licenses to present visitors to see what was being done at CERL. Zenith produced phosphors for Edward Scarpelli (BSEE '66, MSEE '68) master of a multicolor plasma display. Early press reports prophesied potential as a new TV.

PLATO would require a better display for the long haul.

Bitzer enlisted Willson, then a graduate assistant, and Slottow, then a research engineer, in the task of exploring how a matrix of discrete neon cells might be driven by a high-frequency ac current, using capacitors at each cell so that individual cells, or pixels, could be addressed. The big breakthrough came one summer evening as Bitzer and Slottow waited outside CSL for their wives to pick them up after work. They began discussing the project in terms of its barest essentials and realized that the simplest configuration would be to exploit the natural capacitance of the glass on either side of a panel, which could be done by placing electrodes on the outside of each cell, separating the driving current from the gas.

Next morning, the team set about building a new device. With Willson doing most of the handwork, they ultrasonically drilled a hole fifteen thousandths of an inch wide into a thin glass slide, then sandwiched that slide between two others. They deposited thin-film gold electrodes on the outside surfaces to carry a high-voltage driving source. They sealed the sandwich with epoxy on three sides and glued it to a vacuum pump on the fourth, then pumped it clean and backfilled it with neon.

Power on. Blue.

It was July 1964, and the first ac plasma display panel had been built. The panel's single cell operated on the fundamental rules that govern the millions of cells in one of today's panels.

A 4 x 4 pixel plasma display. Graduate student Brij Arora (MSEE '68, PhD '72) built the first multipixel display. "We could address the lines to write the character or erase it. It was a very exciting thing," recalled Arora. (D. L. Bitzer)

After this initial success, the team learned that nitrogen from the air had

leaked into their cell, accounting not only for its blue hue, but also for its good "memory margin"—its property of remaining lit in the presence of a "sustain" voltage significantly lower than the "breakdown" voltage necessary to initiate the discharge. By 1967, the inventors had figured out how to achieve good memory margin using just neon, and they had developed the driving circuitry necessary to address a large array of pixels. (Alpert had kept Bitzer's research under his wing after becoming graduate college dean in the mid-1960s. After the move, Bitzer's lab was renamed the Computer-based Education Research Laboratory.) That year, they built a 16 x 16 panel that glowed orange, thanks to the purer neon mixture. PLATO screens and other plasma panels for years to come, here at the U of I and beyond, would radiate the same orange.

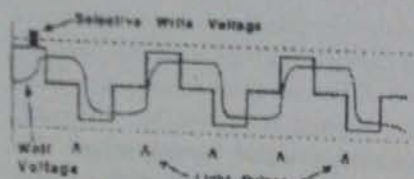

A 16 x 16 pixel "UI" display from 1967. (D. L. Bitzer)

In its "on" state, a plasma cell actually flickers thousands of times per second. Every time the ac sustain voltage reverses polarity, its corresponding field within the cell realigns with an alternating "wall voltage" emanating from the glass, creating a total cell voltage sufficient to ignite the discharge. A new wall voltage of opposite polarity then begins to build up until it cancels the cell voltage, extinguishing the discharge, and a new cycle begins.

The History of Plasma Displays III. Seeing green

By Jamie Hutchinson

Patent attorney Nate Scarpelli (BSEE '58) was new to the Chicago law firm of Merriam Marshall Shapiro Klose when the firm assigned him the task of

patenting PLATO, the plasma display and other ideas for the U of I. "Merriam" was Charles Merriam, who sat on the board of the U of I Foundation and was the driving force behind University Patents, originally set up within the Foundation to license publicly held University Patents. The push was on to commercialize U of I technologies—a new and controversial course for the century-old land grant institution—with an eye toward building the university endowment.

Although the first patent covering the fundamental operation and application of the plasma display panel was not granted until 1971 ("one of the most complete applications I think I've ever done," recalls Scarpelli), U of I began collecting on the technology as early as 1967. That year U of I sold an exclusive license to the Owens-Illinois glass company, which would deliver the first commercial-grade "Digivue" display for use in PLATO in 1971.

An Owens-Illinois "Digivue" panel with electronics exposed. (Owens Illinois)

IBM took an early interest as well, and the lure of Big Blue's prestige and deep pockets forced Merriam and Alpert into some ticklish negotiations between the two corporate players, with the happy result that U of I collected a million dollars from IBM in exchange for another license. That license would lead in 1983 to the IBM 3290 Information Panel, "the industry's first mass produced, large-screen plasma display terminal for commercial use," according to an IBM advertisement.

TV companies including RCA, Zenith and General Electric took notice of early press reports about plasma displays as potential "hang-on-the-wall" TVs. Some took out licenses, but they all sent visitors to see what was happening at CERL. Zenith provided the phosphors for Edward Stredde's (BSEE '66, MSEE '68) master's work on a multicolor plasma display. Early press reports prophesied plasma's potential as a new TV display.

technology. This article from the Minneapolis Star pointed out the role of Minneapolis-based Control Data Corporation in PLATO. A CDC computer replaced ILLIAC as the PLATO mainframe, and the company brought limited rights to the PLATO name in the late 1960s. (Minneapolis Star)

After finishing his PhD in 1975 with a dissertation on the discharge dynamics of plasma displays, Weber joined the CERL staff and began consulting to U.S. companies interested in such commercial applications of the Illinois technology.

Another CERL alum, Roger Johnson (BSEE '65, MSEE '66, PhD '70) joined the ECE faculty in 1971 and found his consulting home in the Pentagon and its contractors, which included Magnavox, Science Applications International (now SAIC), and the Owens-Illinois spin-off Photonics Systems. Johnson would leave his faculty post in 1977 and spend the next 25 years at SAIC developing flat displays and mobile workstations. In 1982, the company manufactured its "Plasmascope" displays for controlling ground-launched cruise missiles. The displays were "nuclear hardened" to withstand the radioactive environment of a

nuclear war. Similar displays went into the Trident nuclear attack submarine and the "Doomsday Plane"—officially known as the Advanced Airborne Command Post, a Boeing 747 outfitted to control U.S. forces in a nuclear war. Photonics and Magnavox collaborated on the largest plasma displays of the time, status boards used by the Air Force to monitor air operations.

Japanese companies were among the first to take out licenses and begin their own plasma display research, enjoying the support and encouragement of NHK, the government broadcasting system that had advocated HDTV as early as the 1960s. Among the prominent Japanese engineers who visited CERL to study plasma displays was Heiji Uchiike, now of Saga University. Uchiike spent a year at CERL in the early days of the plasma display and has gone on to train many of the top plasma engineers in Japan. Japanese companies who sent visitors to CERL, many of them staying for extended periods, include Fujitsu, Hitachi, Matsushita, Sony, NEC, and even NHK. These companies, especially Fujitsu, have made important developments based on the fundamental ideas that came out of Illinois.

Bitzer noted that the Japanese also saw plasma as an answer to the problem of displaying their Kanji script, something the Western alphanumeric computer displays of the early 1960s could not do. So plasma panels became widely used in Japan for cash registers, meters, and public signs.

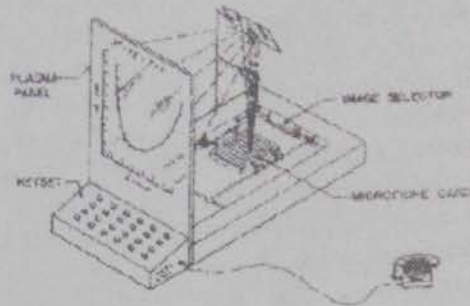

The transparency of the monochrome plasma displays allowed slides to be superimposed on images read from the computer.

Infrared light-emitting diodes on the perimeter of a PLATO "smart" plasma screen could sense the position of a finger. Bitzer summed up the functionality of the PLATO stations: "It spoke, it recorded—if you were teaching a foreign language, you could hear your own voice. It had touch, it had rear projected images, and graphics. You just had to like orange a lot for the graphics." (D. L. Bitzer)



Will iPhone REPEAT THE SUCCESS OF iPod?

Varada Kamat

S.E. (ETRX)

Apple Inc's iPhone, which melds a phone, web browser and media player deepens Apple's transformation from a maker of stylish-but-niche computers into consumer electronics powerhouse already known for its iPod music and video players. The svelte, glassy iPhone is a gamble by Apple's co-founder and chief executive, Steve Jobs, aimed at expanding the market for the company's software and media services.

The phone comes in two versions priced at \$ 500 and \$ 600 depending on memory capacity and requires two years contract from AT & T, with voice and data plan ranging from \$ 60 to \$ 100 a month. Apple iPhone hit store shelves on 29th June in a consumer spectacle that whipped gadget fans into a frenzy over a device that challenges business as usual in the mobile phone industry. Early reviews have highlighted the large

touch-sensitive screen and full blown web browser, while expressing concern over the quality of AT & T's network, the people iPhone's virtual keyboard and lack of features such as picture messaging. However iPhones had started making itself felt in the industry before even one single unit was sold. In fact rival Palm Inc. said it could post a small loss and lower revenue this quarter due to slow sales and fears the iPhone could not demand for its Treo Smart phones.

Apple iPhone introduces an entirely new user interface based on a large multi-touch display and pioneering new software, letting user's control iPhone with just their fingers. iPhone also ushers in an era of software power and sophistication never before seen in a mobile device which completely redefined what users can do on their mobile phone.

Those eyeing the Apple iPhone in India will have to wait for some more time. The much-talked about Apple iPhone is unlikely to enter Indian market in the next six months. Analysts expect the iPhone to sell over 30 lakhs units in 2007. However the international frenzy over the new iPhone backed by popularity of iPod is likely to bypass India for now.

At a time when India's telecom sector seems to be showing tremendous growth opportunities handset makers see India as an important market. Nearly all players including Nokia, Motorola, Sony Ericsson launch their phones in India simultaneously along with other global markets. It is likely that Apple is giving India the miss and to study the market more carefully.



A politician's welcome for the common man

Looks like the two men are discussing about the country's future!!

Rachit Chandra
S.E. I.T

BE Electronics & Telecommunication



BE Electronics



BE Information Technology



BE Mechanical



IEEE Computers



FSAE Team



CSI Council

IEEE Council



Students' Council



Cultural Team



SAE Council



IETE Council

Foreword

...from nine, thanks to the talent and industry of those from the Rhine, books have emerged in lavish numbers. A book that once would've belonged only to the rich -- nay, to a king -- can now be seen under a modest roof. -- There is nothing nowadays that our children -- fail to know".

Sebastian Brant, written about the printing press just after 1500.

In 1440, centuries before Michael Faraday would have even thought about Electromagnetic waves, German inventor 'Johannes Gutenberg' invented what is popularly known as printing press. A process that, with refinements and increased mechanization, remained the principal means of printing until the late 20th century. A process which meant printing from movable type, including the use of metal molds and alloys, a special press, and oil-based inks, allowed for the first time, the mass production of printed books. A process which arguably was one of the essential ingredients of the Industrial Revolution. By 1499, an estimated 15 million books had been press printed, representing thirty thousand book titles. In 1741, the first magazine in America named 'American Magazine' was published. Over these 600 years, books and magazines have grown not merely as a source of entertainment, but also as an important means of communication; and more importantly, as a culture. And here in 2007, we bring you our annual college magazine- 'Kshiti' 07'.

Being the Jt. Magazine Secretaries of the council has almost been like a roller coaster ride. By the end of the

year what we have realised is that more than just being the magazine secretaries, we were a part of the Students' Council 06'-07'.

Permissions, plans and preparations have actually been a part of our routine throughout the year. (What the above implies in our context is that we were the people who ACTUALLY FRAMED the permissions, plans and did the work that MOST OF THE COUNCIL takes for granted: (all the best to the next magazine team). And after Symphony got over with all of its exhilaration, frustration, joy and quite a few fist fights, our real job as mag secs actually begins. So while the rest of the council relaxes (We are going to be crucified by our mates in the council for writing this foreword), we commence our task of running from pillar to post. And anyone who feels our job is easy can try reading through a 100 articles containing absolute nonsense and tell me about the experience(if he lives through it).But jokes apart it was a real pleasure working with a team like ours and it really has been a fantastic experience which has taught something to everyone. We have learned a few things like dealing with pressure and meeting deadlines that others will perhaps learn later in life.

An era has come when new forms of media have completely outdated the print media in terms of speed. But still, what we personally feel is that books, newspapers and magazines continue to be an important part of our life. The amount and immediacy of information on the Internet is unparalleled, but it has not signaled

the end of the print media's relevance. Newspapers in print remain a popular and powerful medium for the reporting and analysis of events that shape our lives. WAN estimates that one billion people in the world read a newspaper every day. Even when it comes to the college level, the magazines are an important means of your communication to the rest of the college. It's almost like a stage where you can stand and express anything you would wish to. We've certainly tried our level best to incorporate most of the contributions in some way or the other. At the end of the day, it's upto all of us to decide whether to read our college magazine or turn on our T.V sets. The choice is simple. The decision is ours. Of course!!

Sohit Raina

Rutvik Sheth

(Jt. Magazine Secretaries)



The Voices of our Gurus

Priya Mathur

T.E.(Extc)

It's been 24 years since 1983 that Somaiya has been producing avant-garde engineers who are shaping the new technology. In this journey of our Gurukul, we have had mentors who nurtured the young buds to become whippers of technology. Technology has moved ahead and so have we, but the only thing which is left behind on our way are our roots, our 'GURUS'. What makes me more sad is the fact that their voices were never heard in the battle of students and management. This persuaded me to make an effort to communicate their voices to you. Check out what our professors have to say to various questions that come to mind!

1. What are the changes that you have seen in Somaiya over the years?

GOOD ONES

It has grown in infrastructural facilities for both students and faculty.

Ms. Mita Gandhi (Mech)

BAD ONES

Students have become less interested in lectures. They go for classes and have become more examination oriented.

Ms. Mansi Manoj Kamble (Comps)

2. What do you like most about your department?

It's a cool department with no burden on your head.

Mr. Om Prakash Yadav (Comps)

The Spirit of doing innovative things

Ms. Hetal Doshi (Extc)

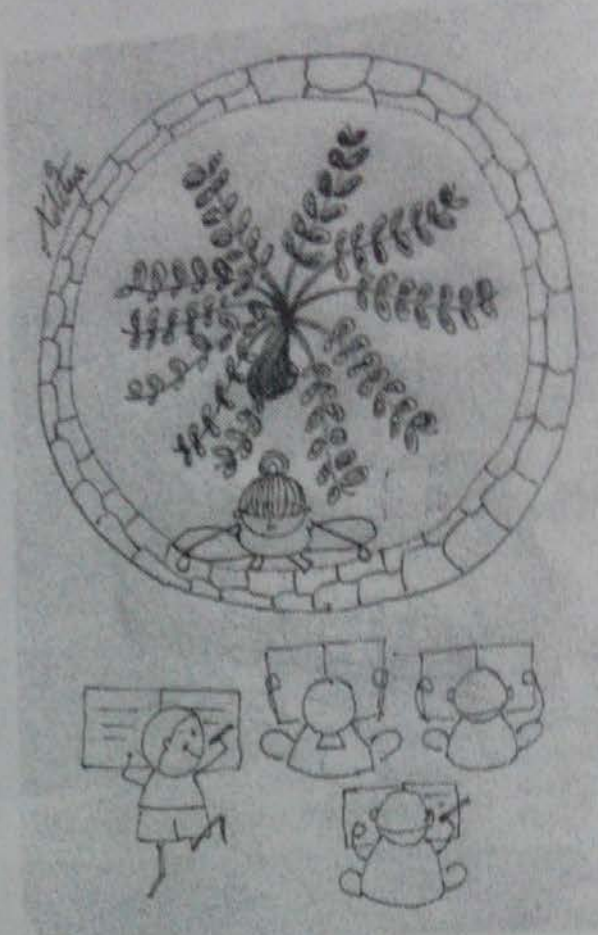

3. What do you think about the student teacher rapport in our college? How can it be improved?

Students' attachment and a sense of belonging have deteriorated over the years. They are less adjusting and more demanding now.

To improve the situation, I think parents have to inculcate the respect for others in their wards.

Mr. A.K. Choudhry (Dean of Academic Affairs)

It has become friendly but sometimes students take teachers for granted. They should know their limits.

Ms. Mansi Deshpande (I.T)

4. According to you, what is the reason for fewer engineers opting for the teaching profession?

In the present scenario, more industrial jobs are available with attractive financial packages. The employers like Infosys, provide training for the latest technologies whereas in the teaching field such facilities are not provided. Also, the system to offer incentives in proportion to the performance does not exist.

Ms. Kundargi (Extc)

5. What do you think should be done to improve the situation?

Salaries should be hiked with more incentives and there must be research facilities for

teachers.

Ms. Mansi Deshpande

6. Your reaction to the recent fee hike in the college?

It could have been more transparent.

Ms. Hetal Doshi

It is justified since you can't do all the things for yourself. You have to contribute for the future benefits of others.

Ms. Mita Gandhi

7. What is the one thing that you think your department can improve on?

I think they should restrict their staff

Thou Shall Call Me A Loser.

Nimish Tanna

T.E.I.T

...leaving. Also something should be done about the payment. There should be some incentives for professors. The staff will be encouraged if there is more of research work and paper presentations.

Ms. Om Prakash Yadav

I believe they should have more lab facilities.

Ms. Hetal Doshi

What are the changes that you would like to see in the curriculum?

Assignments should be removed. Also, more projects should be given to students. More seminars should be conducted. Also, I think extra curricular activities should be there in college. Apart from these things summer internships with a proper time slot should be there.

Ms. Kundargi

I think more seminars should be there. Also no assignments should be given. More practicals, projects and workshops will make the curriculum effective.

Ms. Mansi Manoj Kamble

Other than college work, what other means can students use to gain a sound technical knowledge?

Independent projects and technical paper presentations will help students to have a sound technical knowledge.

Ms. Mansi Deshpande

Through research papers and journals, students can gain technical knowledge apart from college.

Ms. Mita Gandhi

I remember myself answering calls for my dad from my college for the lowest attendance ever recorded. I remember myself getting caught signing proxies for friends, being thrown out of the class at least once during a lecture and doing everything else besides studying but I don't remember ever thinking seriously about my career until I joined the **Indian army**.

I failed in the final conference interview in my first **SSB** (Service Selection Board) interview. I was so disappointed but I didn't lose hope. I applied again, got the call and made sure that I don't repeat the mistakes and I got through the final selection with 9th rank in the all India merit list with just 85 vacancies in my course.

I was so desperate to be a part of the army that I quit my engineering degree in which I had already completed 2 yrs to join the 10+2 TES course at the **Indian Military Academy, Dehradun**. I still cannot forget the series of farewell parties I had.

Finally, the day arrived when I was standing in the academy.

My eyes were too small to capture the entire glimpse of our nations' most prestigious and honored structure- "**THE CHETWODE**" building of the IMA. I still couldn't believe this was happening.

From the day I stepped in, I had stepped out of the world. It was altogether a new world full of hungry mammoths all over in an ambush to pounce on you on 1 single error. I felt like a lost creature in the world. I started spending days and nights running all over for miles without any clue of days & dates, hungry stomach, tired muscles, no time to think, sleep, eat...just kept running to meet deadlines for lectures & training sessions. During all this, I suffered a

severe swelling in my thighs due to excess stress. I spent about 21 days in the military hospital getting treated for the same. It was during this time when I could actually sit & look at myself. Doctors said I had bent my thigh bone and it might even break in my 5 years of training. And if this happened, I would be landing nowhere with just a 10+2 qualifications. I had to make a quick decision. I said I'll "**quit**". I realized that it was not an easy decision after my years of dedication to it. I always wanted to do it but now it's me calling it to quit. I never wanted to run away from problems or difficulties but I felt I had to take a calculated risk. "This is not the dead-end", I said to myself. The outside world still has opportunities for my career. So I came back, resumed college but had to lose a year because of no attendance for 3 months.

People started calling me a loser. But I believed that realizing one's limits and capacity were more important than an ego which would drag you to do things just because you asked for it. I knew it was I who had promised everyone that, "I will return only when I had stars on my shoulders." But maybe I was coming back with a loser in me.

I had promised myself to accept the criticism without a grin. I realize I had spoiled my family's expectations but I had also developed an aim to win those expectations back.

This attitude is not because of shamelessness but because I have not yet accepted myself as "loser". There are phases in life when you dream something but things turn up differently. There are times when you have to face defeat but what is more important is what you learn from it. I still get to hear comments. "Hey! Look, he's the one who ran back from the army", is something that I am used to now.

Enliven My World

Sanskriti Nagar
TE IT

In my failure times, there were my parents and a few "real friends" who stood by my side. I owe them a lot.

Today I am still in the process of establishing my career and achieving my goals but I have not yet left hope and won't even stop trying because the principles and the lessons that I learnt during my short training in the academy will never let me do it.

But it also doesn't mean that I am going to be a complete changed human. I am still the very same. I still bunk lectures, have low attendance, often get thrown out of the class and have my part of the fun. But I know my job and have learnt that defeats and criticisms shouldn't make you weak or feel depressed. Instead face it, overcome it and live life to the fullest.

This experience has taught me things which have certainly changed my perspective towards life which I can never forget.

So I thank the "Indian Military Academy" for creating a stronger person in me.



ANSWERS to the Somaiya Quiz (Claim to know your college?)

1. 1983
2. Dr.(Mrs) Medha Dixit
3. 4
4. Somaiya Institute of Management Studies and Research
5. 6-College Canteen, Management Canteen, Café, Hostel Mess, Suruchi canteen at the entrance, Polytechnic canteen
6. Near the canteen
7. 4, Dr. A.K.Choudhry
8. Tadmaya Vyakhyan Mala
9. a. Potential
b. Tatva-Convergence
10. Opposite to the Management Institute
11. Badminton court
12. Ladies' Representative
13. Common Computing Facility
14. Manchurian Rice
15. Near the Hostel Mess

Come enliven my world,
Fill it with joy and fun.
Take me in your stride
Allure me, entice me.
Fill this void with your presence.

Lighten up the dark alleys,
Unearth the hidden vaults,
Break away their seals and locks;
Let me flow free.

Be my guide tonight,
Take me to distant lands,
Flying on a magic carpet,
Over the desert's sands.

Far away from this world,
In a world filled with love,
Where there dwells no other soul,
Only you and me.



Life's Like That.....

Rachit Chandra,
S.E.I.T

No way when seen
No where when it seems.....
Walk Walk Walku will find one scene
Soothing to your eyes ,touching your soul
You get involved with your heart wide open
All of a suddenthe clouds of truth
Make you realize ... it was nothing but an unfulfilled
dream.

Life seems tough
Things change, people die , you become a passer by
The stains of stress , the marks of despair ...
Becomes dark with each tear....

The castle of success looks miles away
The trials of your game have nothing to say
Walk Walk Walkyou will find one scene
Promising to rub away the turns of your path
Trying to make you get rid of the scarce.....
All of a sudden ...the clouds of truth...
Make you realizeit was nothin but an unfulfilled
dream.

After a while
A little smile on your face
The infusing steps of your pace
Gives you the power to get up and begin again.
Do not worry ,this is not another dream
This is real life...
The time to live it up has come...
Walk Walk Walkfulfill your dreams...

FAITH

Jayesh Chande
T.E ETRX

Come December and the flood gates open,
The tide of memories sweeps me along,
When not so long ago, a dream came true,
Life was so perfect a beautiful song.

An angel appeared in the guise of my son,
A divine birthday gift from the lord.
One day after Christmas I had been born,
History repeated itself by the grace of god.

Many a times I had chided my mother,
Why I was not born a day before.
As the whole world would have celebrated my birthday,
With pomp and splendour and festivities galore.

The wheel of time churned and now it was my mother's
turn,
To gently rebuke me for the delay.
You missed the great day, just like me,
We are but puppets in God's great life play....

God gives and just takes away,
Some buds bloom, some fade away.
It takes a second to change your life,
Who can understand destiny's charade.

A thought escapes from my memory bank,
And often fills my eyes with tears.
Remembering my son's priceless words,
Who was wise beyond his toddler's years.

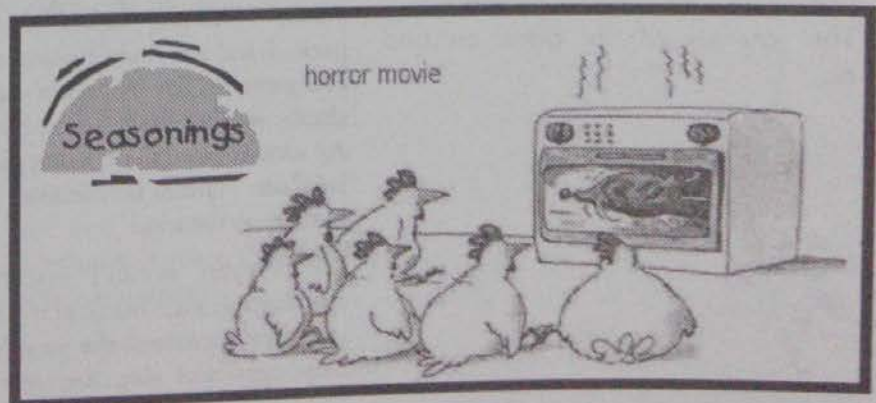

I bore it all with deep faith,
That god will find a way out.
So I taught my loyal two-year-old,
To fold his hands and pray.

Freylin

Sanskriti Nagar
TE (II)

Prayer is a boon for the human race,
A soothing balm for the tortured soul.
Its roots are deep in the innermost
self,
Prayer blends an individual, into a
complete whole.

There are no rites and rituals in true
prayer,
The connection is from deep within.
God is moved by noble thoughts,
And presence of faith- deep, calm
and serene.

The prayer that arose from my
anguished heart,
A plea to save my son's last breath.
Was lost in the winds of destiny's plan,
And collapsed in the deadly face of
death....

In my dream, God was the holy
mother,
Basking in a halo of divine love.
And holding her hand was my
precious son,
Smiling, assuring me, all was well.

The tears stopped, my strength
returned,
Each day brings me closer to God.
I am grateful for all the blessings I
have,
The journey of life goes on and
on.....

If I said that Freylin is a dull, grey
place, I wouldn't be doing enough
justice in helping you imagine the
place. But just to give you an idea, think
of a warm, sunny beach with tens of
tourists sunbathing, as the waves break
gently on the shore. Now think of a
place with snow-capped mountains and
green valleys, where honeymoon
couples cuddle in their beds. I'm sure
you pretty much get the hang of the
feeling I'm trying to create. Well, Freylin
is a place entirely opposite to the feeling
you are having right now. It doesn't
beckon any smiles, laughter or even the
faintest traces of happiness. Freylin is
simply devoid of any emotion.

I happened to be in Freylin because of
my cousin Jessy. It is her work that
demands her to stay there, but she likes
the place. 'How can you Jessy?' I asked
her, for I couldn't see what was so
seemingly likeable about that place.
'Well, once you start staying somewhere,
you simply start liking it'. Although it
isn't reason enough for me, it was for
Jessy, and so she had been staying in
Freylin since the past two years.

I had been visiting Jessy for a few days,
and was to get her back home for
Christmas. It was the time of our family
reunion. Back home in the south, it was
a season of festivity. December, after
all, is the time when you go out
shopping for your loved ones. The
streets are dressed up and adorned with
small, twinkling lights. Shops are
packed, and you find Christmas goodies
everywhere. The churches have their
choirs singing their Christmas Carols.
All around you, there is happiness and
laughter. There is blessing and joy
blowing in the wind.

But Freylin doesn't inspire those
emotions. It stays blank as if a smile has
never ever crossed the town's streets.
This particular day, the weather was



rougher than usual. The north always
had a lot of snow, but Freylin has even
more. I wasn't in the mood to go
indoors, despite the threatening
weather outside. I wanted to walk
around, see the place that didn't give me
nice words to describe it. I wanted to
find those words.

I stepped out much to Jessy's
frustration. 'You know its bad outside,
Jessy had every right to worry. But I
wasn't going to walk too far away. I'll
be back soon. I promise.' I'm known
in my family to be very stubborn, and
Jessy didn't stand a chance trying to
dissuade me. She agreed, reluctantly
though. 'Keep yourself warm.' 'I'll be
warm Jessy.' I said, beginning to feel
exasperated. I'm not a kid anymore and
I hate being treated like one.

I stepped out, as Jessy shut the door
behind me. The minute I crossed the
threshold, I forgot how warm I had
been just seconds before. 'Gosh! Can I
even get this cold?' I wondered. I

snowing lightly, and the wind wasn't blowing too strongly. Yet, as it touched my face, it stung. I kept my head low, trying to avoid the wind in my eyes. Still the cold was getting to me. Despite me being wrapped up in a woolen shirt with a heavy jacket and an overcoat, the chill was brushing against my bones.

I always had the impression that any human settlement, no matter how ancient, remote or modern is an assortment of colours. Man's ability to recognise three primary colors, create secondary colors from them and blend them into a wide range of shades and blues, has led him to use these colours creatively in his art, work and living. But on the streets of Freylin, you don't see such a variety. Or you can't distinguish between them. I'm certain the houses that line the streets must be painted white and blue and even red perhaps, but your vision will only behold grey in such weather. As I passed one house after the other, I could clearly see through their distinct styling and shapes but not colours. In fact, the only color besides grey that day, was the blue-grey of the sky and the silver of the road I walked on. This silver is not the silver that is used as jewellery to adorn a woman's body. It is the silver of a sharp, steel knife.

And as I walked towards the bakery, a few blocks away, I was beginning to see the chill, hear it. It was as if, the chill was an entity that was walking along with me that afternoon. There was hardly anyone on the street, all of them wise enough to enjoy the warmth of their homes. But I kept walking, taking in the coldness and the wetness of the day.

As I turned round the corner, I saw the bakery, with its half-open shutter. It didn't have any twinkling lights or any streamers to suggest that the townspeople were nearing Christmas. The only light in the shop that I could see came from a single bulb, suspended from the ceiling. I quickened my steps, when I heard something.

Now, it shouldn't be surprising for anyone to hear someone when walking down the road. And even I shouldn't

have been surprised. But I was, for whoever it was, was talking to me. 'Hiya Lady! Out for Christmas shopping eh? Not a good weather, though I've seen worse.' The voice speaking to me belonged to a man whose age I couldn't guess. He could have been old or very old or even not that old, but his face was hidden and I could only see the outline of his body.

He was huddled in a corner of a building, where perhaps, the wind didn't hit him directly. And the snow didn't fall. But he was far from being warm. He was shabby, wearing nothing more than a shirt and was trying desperately to keep himself warm by using newspapers.

He had pulled them close to himself and had tried to wrap himself in it, but the wind was challenging his attempts. The newspapers were providing him with a feeble cover. His voice was shrill and hoarse yet it didn't have any coldness in it.

He smiled at me, as I looked at him. 'Ah! Young lady. Merry Christmas!' He waved, and then turned his back towards me and began preparing the ground for his sleep. I watched him, why, I don't know, but I didn't move from there. I watched him as he lay on the ground and shut his eyes.

There are times when you want to run away because it's cold and freezing, the bakery isn't inviting enough and a stranger has wished you Merry Christmas with a spirit that claims that the celebrations are on in full measure. But you know that isn't true, and you want to run away because you are afraid that the next man you meet would probably claim that the weather is just perfect.

But I didn't want to run. Although the things happened just like they should have happened, had I decided to run away, it wasn't an insanity that had spoken to me. It was happiness. Happiness even in a place that didn't promise as little as a smile.

I walked upto the man. I knew he wasn't asleep because he was shivering, but he

had his eyes shut as if lost in a pleasant dream. I took off my overcoat and placed it on the man. It covered him well, he being of small structure and me being comparatively heavy-built.

If he felt the coat on himself, he didn't give any indication of it. He continued to sleep with his eyes shut. But he had stopped shivering.

After baring my overcoat, I had expected myself to start going numb. Wasn't I already freezing before? But that didn't happen. Instead I felt a warmth spread through me. I looked up at the sky. It was still the colour it had been before, the wind was still blowing, and the snow still falling. And yet, I had begun to feel warm.

I smiled to myself. There wasn't anything that had changed in the past few minutes. Not the weather, not the streets, not the colours. Only the overcoat had changed shoulders.

And there it was, in that afternoon, that I realised what had made the difference. I, under the coat was just as frozen as that man under the newspapers. And yet, when I gave my coat to him, he was warm under it, while I was warm without it. It was the gesture that had brought warmth to both of us. It was the indication that the coat would be useful only when it belonged to the right man.

And there, I had my words to describe Freylin. I had, for the first time in days, felt Christmas in my heart. I had the feeling there, right on Freylin's streets.

That was the present I left behind at Freylin. In the cold, grey streets, I had kindled a fire that would last one Christmas for someone.



Oscars and Indian Cinema

Darshan Rajendra Divecha

T.E. Etnx

Introduction

There has always been a sense of derision built into the word "Bollywood," a slang term for the commercial side of the Indian movie business that was supposedly coined in the late Seventies by a gossip columnist in Bombay. That origin story may be apocryphal, but it rings true anyway, because the word itself has a "Who-the-hell-do-they-think-they-are?" subtext. "Bollywood" is exactly the kind of tag that a jaded (and envious) journalist would invent, and it makes sense that it has become a sore point with Indian film professionals and fans who resent the implication that the country's entire movie industry—which produces over a thousand films a year in more than a dozen regional languages, for an enraptured global audience of over a billion people—is merely a jumped-up imitation of the real thing. But this controversial term continues to be widely used, in part because it offers a useful way to refer to Indian popular cinema, both as an industry and as a world apart. As a matter of fact, Hindi cinema is our closest neighbor. It has its own world, its own traditions, its own symbols, and those who are familiar with it understand it." On the other hand, Oscar is just a convoluted term used for Hollywood cinema. They are just the awards given to movies, but they have been symbolized as the Hollywood.

Oscar

It's been called "the Academy statuette," "the golden trophy" and "the statue of merit, the iron man." Born in 1928, the Academy Award of Merit - which we know as simply "the Oscar" - depicts a knight holding a crusader's

sword, standing on a reel of film with five spokes, signifying the original branches of the Academy: Actors, Writers, Directors, Producers and Technicians. This statue weighs 8.5 pounds and is 13.5 inches tall.

The statuette was designed by MGM's chief art director Cedric Gibbons.

The Origin of The Oscar Name

A popular but unsubstantiated story has been that the moniker caught on after Academy librarian and eventual executive director Margaret Herrick said that the statuette resembled her Uncle Oscar.

Oscar has changed his look on occasion. From the 1930s through the 50's, juvenile players received miniature replicas of the statuette; ventriloquist Edgar Bergen was presented with a wooden statuette with a movable mouth; and Walt Disney was honored with one full-size and seven miniature statuettes on behalf of his animated feature SNOW WHITE AND THE SEVEN DWARFS. In support of the World War II effort between 1942 and 1944, Oscars were made of plaster, to be traded in for golden statuettes after the war. Additionally, the base was raised and changed from marble to metal in 1945.

Results were given in advance to the newspapers for publication at 11 p.m. on the night of the Awards. As a result, the sealed-envelope system was adopted the next year and remains in use today. While the first presentation escaped the media, an enthusiastic Los Angeles radio station covered the second banquet during a live one-hour broadcast and every presentation since then has had broadcast coverage.

History

The first Academy Awards were given on 16, 1929 in the Blossom Room of the Hollywood Roosevelt Hotel. The attendance was 270 and tickets cost \$1.

The first 15 Awards presentations were banquet affairs held first in the Blossom Room, then at the Ambassador Hotel and Biltmore hotels. The 16th Awards ceremony was held at Grauman's Chinese Theater and was covered on network radio for the first time. After three years at Grauman's, the Awards moved to the Los Angeles Shrine Auditorium. The presentation was first televised at RKO Pantages Theater in Hollywood on March 1, 1953. The Oscars were first broadcast in color in 1966. ABC has televised the show since 1976 and is under contract through 2014. The Awards moved back and forth between the Shrine and the Music Center. The Awards returned to Hollywood for the 2001 (74th) Annual Presentation at the state-of-the-art 3,300-seat Kodak Theatre in Hollywood & Highland.

In 1927-28, *Wings* was the first film that won an Oscar for the Best Film.

The Oscar for best director: *Ben Hur* Borzage.

The Oscar for best actor: *Emil Jannings*

The Oscar for best actress: *Janet Gaynor*.

Maximum nominations for a director: so far, 12 and to William Wyler.

Maximum awards for best director: so far, 4 and to John Ford.

Few unmissable movies would be *Casablanca*, *Titanic*, *Ben Hur*, *the harbor*, *Speed*, *Life is beautiful*, *wars*, *Mission impossible*, *Top Gun*, *Oceans 11*, *Cars*, *Broken Arrow*.

million dollar baby, Cinderella Man, The Godfather, Spiderman, Pirates of the Caribbean, The Departed.

The criteria for giving an Oscar to the movie should be the direction, actors and the story. But there are a few movies which haven't deserved an Oscar. They have been given either on success or on good performance, but usually it is the story line, which should win the Oscar for the best film. But, success is a very small contributor in Oscars.

Apart from Oscars, they also have other academy awards, but they aren't that common among the commoners.

Indian Cinema

Indian cinema includes Bengali, Hindi, Kannada, Kashmiri, Malayalam, Tamil, Marathi, Telugu. In Bengali films, Satyajit Ray was the most honorary person. Bollywood (Hindi) is the informal name given to the popular Mumbai-based Hindi language film industry in India. It is the biggest film industry in the world with 1000 movies a year. The term is also used to refer to the whole of Indian cinema.

Bollywood has its largest diasporic audiences in the UK, Canada, and the US, all of which have large Indian immigrant populations.

Indian audiences expect full value for their money, with a good entertainer generally referred to as paisa vasool, literally, "money's worth". Songs and dances, love triangles, comedy and dare-devil thrills - all are mixed up in a three-hour-long extravaganza with an intermission. Such movies are called masala movies. Bollywood plots have tended to be melodramatic. They frequently employ formulaic ingredients such as star-crossed lovers and angry parents, love triangles, family feuds, sacrifice, corrupt politicians, kidnappers, conniving villains, dramatic reversals of fortune, and convenient coincidences.

There have always been Indian films with more artistic aims and more

sophisticated stories, both inside and outside the Bollywood tradition. They often lost out at the box office to movies with more mass appeal. Songs from Bollywood movies are generally pre-recorded by professional playback singers, with the actors then lip synching the words to the song on-screen. Bollywood films have always used what are now called "item numbers". A physically attractive female character (the "item girl"), performs a catchy song and dance number in the film.

The sheer richness of Bollywood's masala format (a culinary term for a mix of several flavors in a single dish) turns out to be one of its greatest strengths. Indian popular cinema demands an investment of time and patience that may be alien to the shriveled attention spans of modern moviegoers. But in that sense it is also possible that learning to adjust to the long-stemmed rhythms of these films may actually be good for us. Some minor aesthetic adjustments are required, too. As critics like M. Madhava Prasad have pointed out, Indian popular movies have never fully embraced the Hollywood aesthetic of "seamless realism" and disguised artifice, in which the desired effect is a voyeuristic sense of eavesdropping upon secretly unfolding events.

One of the founders of the modern Bollywood idiom, Raj Kapoor, is commonly referred to as "the great showman," and the filmmakers who have followed in his footsteps seem to be equally dedicated to putting on a great show. All the articles collected here, which by design are as different as they can possibly be, have at least one thing in common: they take for granted that it is possible for us firangis to have a direct and personal relationship with these films. And in an odd way it seems to be the stylized unreality of the conventional Hindi movie that makes this immediate experience possible for us. Because no matter how strange these spectacles seem on the surface, you can still get a sense of the hospitable human beings hard at work behind the scenes, pulling the strings for our pleasure

Rang de Basanti, Kisna, Lagaan, and The Rising: Ballad of Mangal Pandey featured foreign actors.

Some of the biggest stars, such as Amitabh Bachchan, and Shah Rukh Khan, have succeeded despite total lack of show biz connections. Some of the biggest actresses in this category are Hema Malini, Madhuri Dixit, Kajol, and Aishwarya Rai.

Amitabh, Aishwarya and Shah Rukh Khan also have their wax statues at madam Tussards museum.

History

Raja Harishchandra (1913) was the first silent feature film made in India

The first Indian sound film, Ardeshir Irani's Alam Ara (1931), was a super hit.

The first movie was released in India around 103 years ago, i.e. on 7th July 1897 at Watson Hotel, Mumbai. This film was produced by Leimour Bros., it had only 6 scenes. It was a silent movie for 10 minutes. The first ever color film made in India was Kissan Kanhaiya produced by Imperial Film Co. in 1973.

Indian films bring export income and foreign prestige to India. In turn, the Indian government gives the Dadasaheb Phalke Award annually as a recognition of a lifetime contribution to Indian cinema. The Award is in memory of Dadasaheb Phalke, considered the father of Indian cinema.

The Indian screen magazine Film fare started the first Film fare Awards in 1953.

Unlike the Oscars, voting is not restricted to members of a specific club or academy, but is open to anyone who buys a magazine and sends in a ballot. Like the Oscars, the Film fare awards are frequently accused of bias towards commercial success rather than artistic merit.

Zee Cine Awards, Star Screen Awards, Stardust Awards, IIFA Awards are few other honorary awards.

Statistics

The Indian film industry is the largest in the world in terms of the number of films produced annually (877 feature films and 1177 short films were released in the year 2003 alone). In contrast, 473 films were produced in the US in 2003.

Also, Bollywood sold 3.6 billion tickets and had total revenues (theatre tickets, DVDs, television etc.) of US\$1.3 billion, whereas Hollywood films sold 2.6 billion tickets and generated total revenues (again from all formats) of US\$51 billion in 2002. Bollywood made a revenue of \$1.75 Billion in 2006 which is only half the revenue of what one Hollywood. India's film business earned \$1.12 billion in 2004, \$1.75 Billion in 2006.

Koi Mil Gaya made \$10 million in India, \$1.9 million from the US market and 1.6 million pounds in Britain, Kal Ho Na Ho made \$8 million domestically, \$700,000 in the US and 600,000 pounds in the UK; Chalte-Chalte earned \$4.5 million at home, \$900,000 in America and 700,000 pounds in Britain. Dilwale Dulhaniya Le Jayenge made \$5 million abroad. Rang de Basanti, a recent

Bollywood release, has collected \$6 million abroad in just 6 weeks.

Oscars and Indian Cinema

Now, talking about Indian cinema and Oscar. Hindi is also a foreign language to the Oscars. So, Hindi movies can be nominated in the foreign language category. It should reflect Indian culture or motivate the future generations. Or sometimes, just the script and critics response makes a team to send their movies to Oscars nominations which are then short listed.

Worth oscar sending movies from the past would be

Mother India, Lagaan, Gadar, Rang de Basanti , Black, Mughal e Azam , Hum aapke hain Kaun, Salaam Bombay, Dilwale Dulhaniya Le jayenge, Sholay, Maine pyaar kiya , Kismet, Rattan , Jai santoshi maa.

Of these movies, Salaam Bombay, Mother India, Lagaan came closest at having a hand at the Oscars.

Then movies like Paheli were also sent to the Oscars in the same year when Black was there. This is what I mean by

commercial success rather than merit. Biasness in Indian cinema is a major contributor.

Conclusion

It's a clear case of sour grapes. A vote of Bollywood tends to disorient the Academy Awards as a Hollywood exercise that Indian cinema can do without. Sure, not winning an Oscar is not going to make a difference to the interface between popular Indian cinema and the masses that patronise it.

But winning one of those coveted statuettes could change the very way the world treats India as a filmmaking nation. It could help our film industry increase its share of the global pie from under one percent - yes, that is where Indian cinema stands at the current juncture - to a level far more substantial.

Despite the hype surrounding Bollywood's increasing influence in the world movie industry, it is a long way from being a threat to Hollywood's influence.

In terms of viewership, Bollywood overtook Hollywood in 2004 and has been leading ever since.



Enormous Spider Web

An enormous spider web has been found at Lake Tawakoni State Park, Texas, US. Closer investigation shows it is not a work of a monster spider but hundreds of small ones. Yet, finding a web this big is rare and truly amazing.

Spider experts say the web is either the work of social cobweb spiders that work together, or it has been created by spiders spreading out from a central point.

Doesn't it remind you of a scene from Harry Potter and the Chamber of Secrets.

Dine Out

Richa Parekh

T.E.(Comps)

Don't know where to take your girlfriend for dinner, or where to take your friends for a treat, are you a foodie and just want to try a nice new cuisine every time you eat?

then here are some excellent places to go to for a candle light dinner, or a family get together.
Eternity Mall, Thane

Here you get yummy barbecued chicken, delicious hummus, fresh juices, etc.

Tabbouleh is out of the world.

Ambience - Place is quiet small but a great ambience

Service - Excellent for a quick chow.

Meal for two: Rs.300

Spice - Fort & Bandra

Food - Chinese

Port Rice which is a mixture of meat, eggs (only veggies also available for vegetarians) and flavoured rice. The Stir Fried Crispy Vegetables are also really good. Garlic rice with paneer or tofu gravy is excellent. Their dessert counter is a die for with desserts like "Death by Chocolate" and "Chocolate Brownie".

QUANTITY of food per plate is huge, please be very careful while ordering.

Ambience - Excellent

Service - Decent

Meal for two: Rs.450

Note: An excellent place if you have to treat your friends or if you're heading in a group.

Out of the blue - Near Carter Road, Bandra

Food - The restaurant specializes in its large variety of fondues and sizzlers. The famous fondues include the mouth-watering and delicious Cheese fondue and the Chicken fondue. The sizzlers include the Chicken Shaslik, Prawns Shaslik and the Tex-Mex Sizzler, of course! For vegetarians, the Paneer Sizzler and the Vegetable Shaslik is fabulous!! One can even create their own sizzler!! The different sauces include cheese, barbeque, mexican, red wine, garlic, pepper and mushroom sauce.

My favourite combination is:

Non-Veg: Chicken with garlic and pepper sauce/barbeque sauce along with mash potato, french fries and vegetables!

Veg: Paneer with cheese sauce with spaghetti and french fries and vegetables! One can even choose two sauces too. Try the masala mafia pasta, it's pasta in white sauce.

Ambience - The interiors are very romantic, sensual, pleasing, sophisticated, coquette...the list never ends. At night, the restaurant is transformed into a beautiful candle light romantic place accompanied by soft, melodious tunes!! There are seating arrangements even outside which takes you far away from the interiors! The meal is laid on low tables and it's like being out on a picnic!! The whole place has a bohemian touch with wooden furniture, old rusted chairs and a glass door with a rope as its handle! (surprising but true!)

Service - Good. Very courteous and helpful staff.

Meal for two - Depends on how much you order like for 1 sizzler its Rs.200 approx. Pasta is Rs.150 and so on. It is expensive but totally worth it.

Note: Ideal for a romantic evening.

Kailash Parbat - Colaba Causeway, Andheri link road (opp. Infinity mall)

Food - This restaurant has excellent chat items, Sindhi dishes, Punjabi and Chinese food. I was too bored of eating Punjabi & Chinese everywhere so I decided to eat some different dishes. I had "Chat platter" which had all chats combined and all were delicious and different. Russian sandwich was heavenly! If you haven't tasted Sindhi food then you are really missing out on something big & here you get "out of the world" Sindhi curry & rice, Aloo tuk, dal pakwaan etc. Other items like pani-puri, bhel, sev puri, ragda pattice are all great. The menu contained loads of other stuff which I am sure will be as good.

Ambience: The Andheri restaurant has a very pleasing ambience, apt for a family outing.

Service: Nothing great as some items took more time while others were served in no time and the staff is not all that efficient.

Meal for two: Again depends on what you order and how much but approx. Rs.200

Quick Reviews:

Pop Tate's - Mulund (W) (R mall), Andheri

Known for sizzlers, Italian, Mexican, Drinks etc. Good food, ambience, service.

Hot Plate - Munish Society, LBS Marg, Opposite Johnson & Johnson, Mulund (W)

Known for good Indian food, Sambar is unlimited and very tasty according to

people who visited, then rajma chawal, dosas & chana masala are very good. Ambience is average but the price is very reasonable.

Ivy- right next to Shopper's Stop, Ghatkopar

Ambience is excellent, vegetarian & non-vegetarian food both is good (separate vegetarian & non-vegetarian menus). The price is a little on the higher side but overall an excellent evening out.

Some eating places that all of us know but still worth mentioning:

- ▶ Gurukripa - Sion
- ▶ Achija - Ghatkopar
- ▶ Peninsula - Sion
- ▶ Khau gali - Ghatkopar
- ▶ Yoko's - Santacruz and many other places now
- ▶ Exotica - Thane (w)
- ▶ Mahesh Lunch Home - Thane (w)
- ▶ Dara's Dhaba - Mira road (w)



Seasonings

```
#include <stdio.h>
int main(void)
{
    int count;
    for (count = 1; count <= 500; count++)
        printf("I will not throw paper airplanes in class.");
    return 0;
}
```

NICE TRY.



The Hostel Fracas

Rachit Chandra

S.E.I.T.

Our sun rises at dusk. The eyelids shut at dawn....With books on our lap but body in bed.... a small glimpse of what is called the hostel fracas.

With dreams in their eyes to carve a niche for themselves but charred with the laziness that vindicates their lives -- is what a hostelite is all about. Well, enough of the complex definitions, now let me throw some light on the intrepid lives of the hostelites.

Friends, you must had been taken aback when you heard the word "hostel". For day scholars, it has always been an enigmatic mystery which needs to be unfoldedthough they try to turn their gaze away from it but as you all know they end up in despair.

Well, the real protagonists are the ones who live it up and become adapted to this venturesome life. People often ask "what is so risky about it???" "Come live it up and you'll get to know the hardships that one has to face " adds Smit Agarwal, a second year engineering student.

The adjustments with the roommates, the abuses of the seniors oops call them sir, attendance problem and the most

important of all, mess food are none the irrefutable grievances of true hostel life. Though we really miss our parents and home but as people it is the story of first year only.... with the advent of 2nd year the fracas comprises the hostelites and the hosteler is our very own hostel. But whenever a hosteler visits his or her home, he would definitely notice a change in kilograms in the body....(an increase in weight course). Awesome homemade food is not the only reason for extra weight, the pampering and love are the other factors to add on.

People often say that hostelers become profane once they enter the premises of a hostel. It is not the case. If you take a stroll in the rooms, you will find some things which will deny the above notion. There are Swami Ramdev fans, but their followers aren't far off and apart from these two, "art of living" too takes a major chunk of their time.

So all you guz out there, what are you waiting for? Just abstain yourself from a normal living and creak out into an adventurous life and find out yourself what this mystery is all about????

Outrage

Rutvik Sheth
SE Enx

I do not know where to begin speaking about the events that unfolded on that Black Tuesday, the fateful day of the Mumbai train massacre. As the events unfolded before us that day, all of us tried calling up near and dear ones to ensure that none of our friends and family was hurt. We were stuck at Ghatkopar for the night and I do not believe that any one of us could understand the magnitude of the loss. We enjoyed throughout the night not knowing even then that so many of our own people were still dying and in pain. I guess the entire thing only hit me when I walked to my house. Never have I seen this in my entire life. For the first time, I saw Mumbai dazed or stumbling over the coming of the next day. For the first time in life I felt so helpless, there was nothing anyone could do to lift this veil of grief that had covered the city. Although the city bounced back to life the very next day and in doing so proved to the world

that the terrorists have failed in their mission of bringing us down, I felt that most of us who were physically fine were mentally grieving for the huge loss that we all felt. We, as Mumbaikars, have been through a lot living in this robust city and have endured through untold crisis, but have never been pulled down by it until now. The enormous death toll and the simple waste of precious life have numbed us. How could anyone be so inhuman to destroy so many lives?

I am a peaceful person and never in my life have I ever wanted to consciously harm anyone. Violence has always alarmed me, but for once my heart is baying for blood and my mind is filled with anger I have not known. We, as the citizens of this country have never really expected a lot from the government. But today I ask for only one thing - I want those responsible for this gruesome act to be brought to justice, all of them right from the financiers,

organizers, trainers and the foot soldiers. For this even if we have to go to the brink of war, that is acceptable. Because these terrorists are like a knife in our backs, the longer they stay the more of their poison they spread but if we pull out the dagger, we will be free from this menace once and for all. Even if we have to bear a little more pain is it not acceptable to be rid of this pain altogether? We have to act now, we have showed a lot of patience, but there is a limit to even our resilience. We have to urge the government to take action and for that I suggest we start a signature campaign to the Prime Minister to not take this lying down. I hope you feel the same way as I do for this act has not only been against us Indians but everything that we stand for- freedom, democracy, secularity and our very right to live in a peaceful world. We can start with this amongst ourselves and then spread this to all Indians. Speak out and spread the word-It is our duty.



Words of Wisdom :

Be creative. Don't be worried about what you are doing - one has to do many things - but do everything creatively, with devotion. Then your work becomes worship. If the atom can have so much energy then what to say about man? What to say about this small flame of consciousness in man? If some day this small flame bursts forth, it is bound to become an infinite source of energy and light. That's how it happened to a Buddha or to a Jesus.

Refugees in their own country

Sohit Raina (T.E Etrc)

Nihaar Handoo (T.E Extc)

Refugee: n. a person who has been forced to leave his country because of war. This is how the Oxford Dictionary 2007 edition defines the word 'refugee'. Ironically, the Kashmiri Pandits happen to be a community which has become a refugee in its own country; a community which was harassed, tortured and forced to flee from Kashmir, their motherland, to save their lives and religion.

Should it be called a tragedy or irony that the pandits were forced to exit from a place where they were born and lived for most of their lives. What forced them to lock their houses and come to plains in peak summers where they could have a cool shade in hilly terrain is a million dollar question. Kashmiri Pandits, the original inhabitants of Kashmir have been thrown out of the valley by some fundamentalists of Kashmir origin with the help of other terrorist organizations. Neither the state nor the central government has been able to control the situation. The exodus of the Hindus from the valley has indeed been one of the deadliest, this world has ever witnessed.

The British divided India, separating the contiguous Muslim majority provinces and divisions to constitute the state of Pakistan and left the Indian States intact, restoring to their rulers. The last Viceroy, Lord Louis Mountbatten, who was entrusted with the task of dividing India insisted upon the application of the partition to the States, and he told the Princes in unequivocal terms to accede to either of the two Dominions of India and Pakistan, keeping in view the geographical contiguity and the demographic composition of their States. Right after the British withdrawal, Pakistan claimed the Jammu and Kashmir State on the basis of the Muslim majority character of its

population and its contiguity to Pakistan, though the 'Muslim League' leaders recognized the right of the Princes to determine the future affiliations of their States. Pakistan conveyed to the ruler of the Jammu and Kashmir state, Maharaja Hari Singh that the Government of Pakistan would support him if the state assumed independence. However, the ruler of J & K, Maharaja Hari Singh chose to accede to India. During the night of 21 October 1947, thousands of Pakistani army personnel, disguised as local Muslim and Afiridi tribesmen invaded the State. Ever since, the occupied area came to be named as Azad Kashmir (or Pakistan Occupied Kashmir) which is separated from the rest of India by what is popularly known as LOC or Line of Control.

The genesis of Pakistan's interference in Jammu and Kashmir lies in its claims that India was partitioned on the basis of religion and therefore the Muslim majority state of Jammu and Kashmir should be part of Pakistan. This pernicious "two nation" theory based on religious bigotry was thrown into the dustbin of history several decades ago when the majority population of erstwhile East Pakistan seceded in 1971 despite commonalty of religion. Sectarian and ethnic riots between Sindhis, Punjabis, Pathans, Mohajirs or Muslim migrants from India are endemic in Pakistan.

Had Article 370 not been incorporated in the Constitution of India, then Jammu and Kashmir would have been placed in the constitutional organization of India in the same manner in which the other federating States, grouped into Part B States, were placed in the constitutional organization of India. Article 370 was not in any way connected with the so called autonomy of the State. In fact, it

placed the State outside the federal structure of India, the federal division of powers between the Union and the States and the jurisdiction of the federal judiciary, including its power of judicial review, which guaranteed the autonomous identity of the States in India.

Today, Kashmir is not merely a district but one of the most debatable and widely discussed topics. Let's see what stand does the 'public' of our college have about it.....

"There was a time when Kashmir, because of its beauty was considered to be the pride of India. But now the conditions have changed, Kashmir today stands for terror and violence."

-- **Rahul Khazanchi**
(T.E I.T)

"It's been more than 60 years now that both India and Pakistan have been fighting over Kashmir. Over these years we've witnessed numerous peace talks, summits and pacts being signed between the two countries. But still the matter has not been resolved. It seems that we are fooling each other."

-- **Vivek Khanka**
(S.E EXTC)

"Whenever we talk about Kashmir, all that we discuss is the root cause of the problem, as in who is to be blamed and may be the possible solutions. No one talks about the great setback that the culture of Kashmiri Pandits has suffered. The community is almost on the verge of extinction."

-- **Vijesh Bhat**
(T.E COMPS)

...hindus are the only
...where the people of our
...do not converse in their
...tongue, simply because they
...never brought up in their own

...some people might claim that
...Kashmir has become much safe
...compared to what it used to be 10
...back. But trust me, you are
...there only as a tourist and
...not as a resident. In fact, that
...is no longer worth living."

...I think the Kashmir issue can certainly
...be solved by mutual talks between the
...countries. This is definitely going to
...take a lot of patience."

"If we've learnt our lessons well from history then there should be no second thought to the fact that India has to launch an aggressive attack on all the fundamentalists who are responsible for the current state of Kashmir."

-- Sanjay Singh
(T.E MECH)

"The only solution according to me is that Kashmir should be made an independent state under a very strong and capable leader, something similar to the case of Bangladesh."

-- Saurabh Gupta
(S.E ETRX)

"The best possible and practical way to deal with this problem is to leave it to the locals residing over there. Let them decide their fate through voting which country they would want to accede to."

-- Arjun Khandelwal
(S.E ETRX)

"Whenever I hear the words Kashmir, India and Pakistan, it reminds me of my 2nd standard days when I used to fight with my cousin for a G-I-Joe. The problem is no longer the control over that peace of land. It has become more of an ego issue for the two countries."

-- Abhinav Madan
(T.E COMPS)

Seriously speaking, it's very difficult to predict the future of this issue. All we can hope is that may be, a day would come when things would be normal at a place which once used to be one of the most beautiful parts of this planet. May be, some day, the original inhabitants of Kashmir would go back to their birthplace, unlock their houses and live with all the norms of democracy. May be, a day would come when humanity would prevail at this place which was once the land of saints.

Only time, we hope, would tell.

Feelings

Aigis T Nalian
B.E. Extc

You cannot feel, the night so beautiful
As she calls me to her, from afar
You cannot feel the angel of peace;
As she passes you by, resplendent,
surreal.
You do not see the army of stars
They beckon to me so, and ask me
to be
One with the earth, one with the
sea.
One with the purity that you
cannot see



I ask you
to be,
more than
a human,
And open
your soul,
to the
power
above

I ask you to be, just like the
miracle,
That you really were meant to be

I need you to feel, the cold chilly
wind

And hear the stories, she wants
you to know.
I want you to care, for the brooks
and the streams,
I want you to be in my dreams...

And I wish you return every night,
again
To show me how beautiful this
world is;
To rid me of suffering, to ease my
pain
To sooth my soul, with a single
kiss...

In A Lifetime

Sanskriti Nagar

TE IT

In a lifetime perhaps,
I won't live life.
But there will be moments,
moments that change life,
that will show me all
that's beautiful
and all that's not.
It is nothing more or nothing less
but I will at times make them
seem more than that
and at times even lesser than
they are.
But the truth stands clear
and unhidden
This is just plain life
and what becomes of it
is what I make of it.



Love for My College.....

Rachit Chandra

S.E, I.T

"Somaiya" the taper of our lives...

Decorated the unexplored
personalities of ours like a
beautiful bride.

The nourishment we sucked
from it ,

Made us understand the depths
of life.

As a caring father,

"Somaiya" evoked the feelings in
heart to be wise by character

At the stage when we were
stagnant water.

It filled our empty vessels with
its glory and glitter.

It's a place where all of us get
the utmost pleasure.

The day is not far when people
will consider "somaiya"
a treasure.

This temple makes you
determined for any mission.

"Somaiya" is a symbol of royalty
and a living evidence
for inspiration.

With the label of "somaiya"
all of us are liked and admired.

So confident are we now, ready
to accomplish our desires.

With time we are becoming more
and more perfect just like wine.

Let's promise to always try hard
to let our light shine.

Waiting.....

Nishant Shah

T.E. (Etrc)

The night ,
The holy New moon night
Creeping in from the fields of delight
Waiting,
for the vampires to yell.
for the hazel light to end

The moans, the groans I hear each
night
Today everything would fall prey to
his might
The gore in my veins would soon
freeze
And my vessels would soon decrease

My breaths are of flickering seconds
Soon the Lord of Death would
descend
Chimes of knell would soon be heard
And I would be ready for a long ride

The augur of death besieged my sight
Off the shores of this deplorable
existence
Anchoring in the world of corpses
sovereign
I have no remorse for the new
experience

With the Curriculum Vitae
I am ready for the Judgement day
For sure,
Hell is the place my soul would repose
And my body is cremated in some
grave

Thus today I cry in vain, in pain
Waiting for the Lord of Death to
descend



Aloneness - The First Lesson Of Love

Jayesh Chande
T.E ETRX

Without the others we don't know who we are, we lose our identity. The other becomes a mirror and we can see our face in it. Without the others we are thrown to ourselves. We are lonely inconvenienced because we don't know who we are when we are alone.

With the other, things are clear, defined. We know the name, we know the form, we know the person - hindu, christian, muslim, american. - these are some way to define others. How to define yourself?

Deep down there is an abyss... an undefinable emptiness. You start emerging into that. It creates fear. You become frightened. You want to rush towards the others. The other helps you to remain out. When there is nobody you are simply left with your emptiness.

Nobody wants to be alone. The greatest fear in the world is to be left alone. People do a thousand and one things just not to be left alone. You imitate your neighbours so you are just like them. You lose your individuality, you lose your uniqueness. You just become numbers, because otherwise you are left alone. You become a part of crowd, a church, an organisation. Somehow you want to merge with a crowd where you want to feel at ease, so that you are not alone.

To be alone is really the greatest miracle. That means you don't belong to any church or organisation, you don't belong to any theology or ideology - socialist, communist, fascist, Hindu, Christian, Jain, Buddhist - you don't belong you simply are. And you have learnt how to love your indefinable reality. You have come to know how to love yourself !!!



capable of love, and a man who feels loneliness is incapable of love. A man who is happy with him self is full of love, flowing. He does not need anybody's love, hence he can give. When you are in need, how can you give?

Loneliness is absence of other. Aloneness is presence of oneself. Aloneness is very positive. It is an overflowing presence. You are so full of presence that you fill the whole universe with your presence and there is no need for anybody.

If the whole world disappears this master will not miss anything; he will be as happy as ever. He will love that tremendous emptiness, this pure infinity. He will not miss anything because he has arrived home. He knows that he himself is enough.

This does not mean that a man who has become enlightened and has come home does not live with others. In fact, only when he is capable of being with himself he becomes capable of being with others. If you are not capable of being with yourself, how can you be capable of being with others?

A man who lives in his aloneness is

You are a beggar. And when you can give, much love comes to you. It is a natural response. The first lesson of love is to learn how to be alone.

Try it, to have the feel. Just sit alone sometimes. That's what meditation is all about - just sitting alone, doing nothing. If you start feeling lonely then there is something missing in your being, then you have not yet been able to understand who you are.

Then go deeper into this loneliness until you come to a layer when suddenly loneliness transforms into aloneness. Loneliness is the negative aspect of aloneness. If you go deeper into it, one moment is bound to come when suddenly you will start feeling the positive aspect of it because both aspects are always together.

A Patron of Art - Adolf Hitler

Abhijat Bedekar

S.E. Etrx

The best of the paintings shows a war-torn streetscape - a lamppost leaning away from a shrapnel-nicked brick building. The background reveals the facade of a gutted church, its purpose burned away. There is no one on the street; life has been chased, bombed, swept from this Belgian village where the soldier-artist found such devastation. The artist was good enough to make his living at this for some years. But he realized he was not going to make his mark as a painter. He changed careers and became far more successful in another line of work. His name was Adolf Hitler.

It is not a coincidence that three of the people destined to be world leaders were all artists to some degree or another. Traditional psychology asserts one of the three areas that define intelligence is visiospatial analysis; the ability to render what you see into another medium. Winston S. Churchill, Dwight D. Eisenhower, and Adolf Hitler all left behind substantial numbers of their original artwork, in essence, a portion of their genius. In the cases of Churchill and Eisenhower, both survived long enough to be able to validate and authenticate their art, usually by means of a letter, or seeing their art presented to the public in published volumes dedicated to their work.

In the case of Adolf Hitler, the only authentication is by third parties. Hitler himself went through the effort to have many of his original pieces of art found, with the intention of displaying them in a wing of the Führermuseum in his adopted hometown of Linz on the Danube in Austria. As events would have it, his preoccupation with taking over the world interfered with his reacquisition of his early art.

Hitler was 18 when he applied to the Vienna Academy of Fine Arts, planning

to make his life as an artist. He flunked the drawing test and was rejected. He resented this deeply and did not try to find a new job or profession. He was told he should become an architect, since he had some flair for making architectural sketches and drawings. He worked as a struggling painter in Vienna, copying scenes from postcards and selling his paintings to merchants and tourists. His intense fascination with architecture was reflected in his numerous drawings of houses, churches, public buildings and city scenes. Hitler believed that the foremost requirement for an artist was the ability to reproduce details of life in realistic. This attention to detail can be seen in his landscapes, city scenes and architectural designs. It is less apparent in his handling of the human figure, which often remained out of proportion, wooden or awkward. He once said at a later date that his paintings could easily be recognized by their "unreal people." Another of his loves, classical music and opera, also appeared as a frequent theme in his art, and he often designed stage scenery and costumes for opera productions for his personal pleasure.

World War I was, as Hitler later wrote, a major turning point in his life. The disastrous outcome for Germany prompted him to devote his life to politics rather than the arts. During the war, he continued to paint behind the front lines whenever he had free time. After the war Hitler turned increasingly to politics and began devoting more time to architecture than to art. By 1919, he had begun integrating architecture and politics, and his preoccupation with city planning reflected specific political goals.

As a private collector and as the initiator of the new museum collection intended for Linz, Hitler was well informed of



the art market prices and the effects of heated collector competition in the Third Reich. When some of his high officials began to bid for art, the intense rivalry inflated prices far beyond what he considered to be a reasonable level. Hitler rejected a "Bismarck" by Lenbach because he considered the price of 30,000 Reichs Marks (RM) far too extravagant. Hitler was outraged that prices of the paintings were soaring out of control and decided that some sort of intervention in the market was necessary. Shortly thereafter, the so called "Fuehrer Option" was put into effect: no picture of historic or unusual artistic value could be sold in Germany without Hitler's permission. This control helped dampen wild price speculation on the art market.

Hitler's sense of appropriate value was particularly accurate in regard to his own works, and he was well aware that his political fame, not his artistic ability, was the source of his market value. Knowing the prices he had received for

Billionaires

Mandar Chaulkar

S.E. Etrix

The annual ranking of the world's richest people was compiled by the American Forbes magazine on 2007. It must have been a busy year for the Forbes' team of fortune hunters. Strong markets combined with rising real estate values and commodity prices pushed up fortunes from Mumbai to Madrid. Forbes pinned down a record 946 billionaires. There were 178 newcomers, including 19 Russians, 14 Indians, 13 Chinese and 10 Spaniards, as well as the first billionaires from Cyprus, Oman, Romania and Serbia.

These folks made money in everything from media and real estate to coffee, steel and ethanol. The billionaires' combined net worth climbed by \$900 billion to \$3.5 trillion. That equates to \$3.6 billion.

The average billionaire is 62 years old, two years younger than in 2005. This year's new billionaires are seven years younger than that. Of list members' fortunes, 60% made theirs from scratch.

Microsoft founder Bill Gates continues to remain the world's richest man for 13 years, and his pal Warren Buffet who holds the No. 2 spot despite enormous charitable donations, are quickly losing ground to Mexico's Carlos Slim Helú.

Helú's net worth is up by an astonishing \$19 billion this year, & is now just \$7 billion less than that of Gates and \$3 billion less than Buffett's. Russia now has 53 billionaires, but they are worth \$282 billion; \$37 billion more than Germany's richest. After a 20-year reign, Japan is no longer Asia's top spot for billionaires: India has 36, worth a total of \$191 billion, followed by Japan with 24, worth a combined \$64 billion.

India's rich are also marching toward the top of our rankings. Brothers Mukesh and Anil Ambani, who split up their family's conglomerate in 2005, joined Laxmi Mittal, who heads the world's biggest steel company, Arcelor Mittal, among the world's 20 wealthiest. India now has three in the upper echelons, second only to the U.S. Surprisingly 300 million Indians live below the poverty line; while top 10% of income groups earning 33% of the income.

But even in such a prosperous year, 44 people dropped off the list for various reasons.

One big loser was a Spaniard, Enrique Banuelos, whose fortune fell 30% in four days.

Next year some new faces will join the list. Some will be out. Let's see.

...in Vienna and Munich, and
...just how much effort (or lack
...had gone into certain works,
...was completely realistic about their
...value. At times he was proud of
...accomplishments, on other
...members of his inner circle
...noticed that he was annoyed
...perhaps even embarrassed by the
...given to insignificant
...of his works. When
...with simple or poorly
...drawings he had done during
...career, he was likely to
...them as "silly efforts of an
...done in a hurry to earn a
... He usually reacted strongly when
...of the prices currently being
...for his art: the higher the price, the
...for his annoyance. When one of his
...purchased an original Hitler
...watercolor for an exorbitant sum and
...proudly showed it to him, Hitler was
...ous that the same picture had
...brought him only a tiny fraction of that
...amount in 1913. He turned to the owner
...and said angrily, "This is obviously a
...fake. I never painted that."



Seasonings

Article 49-O of the constitution

Did you know that there is a system in our constitution, as per the 1969 act, in section "49-O" that a person can go to the polling booth, confirm his identity, get his finger marked and convey the presiding election officer that he doesn't want to vote anyone! Yes such a feature is available, but obviously these seemingly notorious leaders have never disclosed it. This is called "49-O". Why should you go and say "I VOTE

NOBODY"... because, in a ward, if a candidate wins, say by 123 votes, and that particular ward has received "49-O" votes more than 123, then that polling will be cancelled and will have to be re-pollled. Not only that, but the candidature of the contestants will be removed and they cannot contest the re-polling, since people had already expressed their decision on them. This would bring fear into parties and hence look for genuine candidates for their parties for election. This would change the way, of our whole political

system... it is seemingly surprising why the election commission has not revealed such a feature to the public...

Please spread this news to as many as you know... Seems to be a wonderful weapon against corrupt parties in India... show your power, expressing your desire not to vote for anybody, is even more powerful than voting... so don't miss your chance. So either vote, or vote not to vote (vote 49-O)

Rishabh Srivastava
(T.E. EXTG)

A TRIP TO KASHMIR

Nainisha Wavhal

S.E. Extr

A trip to Kashmir distinguishes your life into two halves-before your visit to Kashmir and after you visited Kashmir. After a trip to this unforgettable land, you are never quite the same again. The Kashmir valley, nestling in the lap of the dazzling, snow-capped Himalayas, decked with the Chinar trees and the rapidly flowing Liddar river, takes your breath away, literally.

Kashmir is really as beautiful and as intoxicating as heaven.

The only difference is that the Kashmiri people do not live as happily as they used to. The local citizens are poor and have no jobs to earn their living. Tourism is the main occupation of the people. But because of the militant activities, tourists have stopped visiting Kashmir. The moment the horse riding or sledge driving people see a tourist car, they run after it. A sledge driver was badly hurt when he fell down while chasing our car at Pahalgam. The people here live a hard life. They don't even have proper houses to live.

Kashmir is now a comparatively safe place to visit. The media has hyped the whole thing about terrorism. The border security force(BSF) soldiers are stationed everywhere at short distances for our protection. Earlier, the people used to work for 6 months but now they just have a month to earn for the whole year during the Amarnath Yatra.

It is our duty to support our brothers and sisters in Kashmir by promoting tourism. We must visit Kashmir to help our fellow Indians and once you visit Kashmir, you will agree with me that what began as a dream, lives on as an unforgettable experience.

I Am Not Insane Neither Callous

Nihar Handoo

T.E. Extr

I really don't know what actually is it being in "love" as I have never been, but one thing is for sure that people do change a lot after just having even a flickering Idea about it. Bet me it can move contours of your life.

According to me there has to be no definition of love, it should be instantaneous or has to Take a moment before you get the feel of it...seriously tell u the best and the bad thing about love is that you don't know that you are in "love". But make sure that it is bidirectional other wise its going to be a trouble. You start feeling blissful everyday.

Find good in every thing. Start making faces in the mirror, then giggle naughtily.

You start liking even that person whom you abhor most.

Being a human I also "love" people around me like my pals, my dear parents, but there has to be some one whose presence has to be indispensable in your memoir. Beneath I don't know what I have come up with whether it is a para or a poem, just tried to delineate the immortal feelings of a paramour for his beloved...it goes something like this.....

"I may not get to see you as often as I would like to...

I may not get to hold you in my arms all through my life...

But deep in my heart I truly know that you are the one whom I "love"...

Being with you was as if I was on a roller coaster with an endless voyage ahead.

But gone are the days, now I hardly see you, it pains, don't know why, when I am not able to perceive you..

I am not insane neither callous.. I have a heart that beats for you....

Believe me there is some one in this world who is really happy becos you are and will feel plaintive if you are feeling so.

It's that you don't know how much I care for you..

It's just that I am in love with you.....

"When I look into your dinky eyes...

They appear bella.....

They don't say muchbut still...quite enough to confer with me...

Then I try to find gist of each and every gesture you make, what they mean.....

As if I am in a dark room, altercating with my own shadows which hassle me, hoping against the hope that some day you will come and hold my hand, taking me away from the shades of this darkness.....

I may not get what I want...

I may not fail to remember you.....

But deep inside the core of my heart you will be there till I have a single breath inside me...

Some things are left undone ..

Some words are left unsaid.....

Some feelings are left unexpressed.....

It's just that I don't know how to do this all.....

It's just that I don't want to loose you.....

It's just that I love you a lot....."

Hey now don't get any ideas.....

But ya sooner or later I have to be there with some one,

who will be meant exclusively for me and whose every second of life will be just for me.....

IS SCIENCE RELIGION OR IS RELIGION SCIENCE

Hemprabha Bhatt

S.E. IT

Is science Religion or is religion science? Sounds a bit heavy, doesn't it?

My friends, most of the people consider science and religion to be complete opposites like north and south pole. But is this really so?

First of all, let me ask you something about yourself--"what is your aim in life? Career, Engineering etc. or just aimless, wherever I'll assume a good degree, all right?

But What For?? Take a guess. It's a one word answer---HAPPINESS. The basic aim of any individual is happiness, be it a beggar or a multimillionaire.

Now why does technology advance? To increase the level of comfort, to provide a better life--that is to ultimately increase the happiness in our lives. Thus happiness is the ultimate goal which is measured and tested by science, directly or indirectly.

Now look at religion. What is the goal of religion? Oneness with God. What is God? The upanishads declare that God is Sat-Chit-Anand ie ever existing, ever conscious, ever new joy and happiness.

Are you getting some relation between science and religion??

All the religions declare that God created the Universe. The Vedas, the Koran and the Bible declare that the Universe was created by the holy sound of OM, Amim or the ONE WORD respectively. In his commentary, the great spiritual leader Paramhansa Yogananda writes-The Word, the creative energy and sound of cosmic vibrations, like the sound waves of an unimaginably powerful earthquake,

went out of the Creator to manifest the universe. The Cosmic Vibration permeated with Cosmic intelligence, was condensed into subtle elements-thermal, electric, magnetic, and all manner of rays; thence into atoms of vapour, liquids and solids. Hence the Word was condensed into matter.

Now, for Science: The Big Bang is the most obvious answer for the creation of the universe.

In 2003 scientist K.C.Kole reports that a team of astronomers in 2000, published that the most primordial sound of the universe was a deep low hum that preceded both atoms and stars. It is a simple sound like the mantra OM but hidden within its harmonics are the details of the universe's shape, composition and birth. Further reports say that these harmonic 'notes' rang out like a bell in the first few fragments of a second after the Big Bang and became the seeds of matter which eventually led to the formation of stars, galaxies and our very own planet Earth.

So In Essence, Both Science And Religion State The Same Thing.

Now, Science has given us the famous equation $E=mc^2$ which has led to many revolutionizing theories and ideas.

Light velocity is a mathematical standard or constant not because it is an absolute value in 186,300 miles a second, but because no material body can ever attain the velocity of light. Stated the other way around: only a material body whose mass is infinite could equal the velocity of light. This conception brings us to the the existence of miracles. Masters who can materialize and dematerialize their bodies and other objects and are able to move with the velocity of light and utilize the creative light rays in bringing

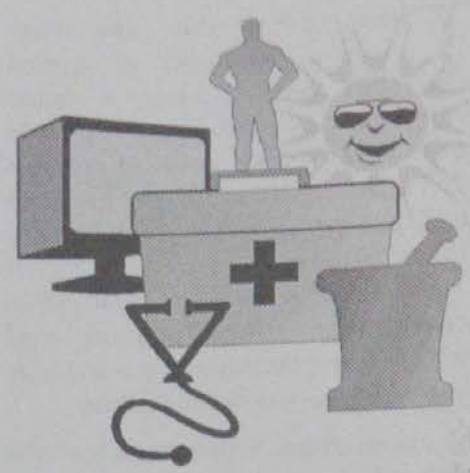

into instant visibility any physical manifestation have fulfilled the lawful condition ($E=mc^2$): their mass is infinite!

Well after reading all this, you must definitely be feeling a link between science and religion that they strive to achieve the same goal. Then why is there always a rift between science and religion---Because their viewpoints are opposite or because they have been putting it across in a different way?

The relation between miracles and inventions is after all simply, "Understandable miracles are termed as inventions while those beyond our grasp are termed as miracles."

Religion is ultimately a set of moral principles which are time tested Living Truths whereas Science is the discovery of truths to live by in modern times.

So in the end I'll finally say, "follow Science Religiously And Scientifically Follow Religion."

Awakening Indians to India

Haricharan L.
S.E.(MECH.)

Transcending the time itself Indian visionaries discovered that time is not a linear Phenomenon but it is cyclic. Not only did they discover the nature of time but they also discovered the precise calculation of this cycle and its part. Looking at the huge span of this cycle it is really amazing to know how Indian astronomers could imagine and calculate it so precisely. This is a unique feature of Indian concept of time.

The importance of the creation of the zero mark can never be exaggerated. No single mathematical creation has been more potent for the general on go of intelligence and power

G. B. Halsted

The discovery of zero is probably one of the few areas where India is accorded its rightful standing in the development of mathematics. This is not known for certain that who invented zero and when? But it has been in use right from the Vedic time. The importance of zero is manifested by its wide spread use in today's world. This discovery is the one that has helped science reach its current status.

Apastamba, the great Indian geometer and author of 'Apastamba Sulba Sutras', for the first time, gave a remarkably accurate value for square root of 2, as equal to $=1+(1/3)+1/(3^4)-1/(3^43)$, which gives an answer correct to six decimal places.

It is India that gave us the ingenious method of expressing all numbers by

ten symbols, each symbol receiving a value of position, as well as an absolute value. We shall appreciate the grandeur of this achievement when we remember that it escaped the genius of Archimedes and Appolonius.

Pierre Simon De Laplace

The song "Jana gana mana..." composed by Rabindranath Tagore, was adopted by the Constituent Assembly as the National Anthem of India on January 24, 1950. It was first sung on December 27, 1911 at the Kolkata Session of the Indian National congress.

"Vande Mataram..", National song was composed by Bankin Chandra Chatterjee on November 7, 1875.

UNREQUITED LOVE

Abhiram Bajpai
BE Extt

A Queen of ancient times,
Mystic eyes filled with tales of
another life..

I take a peek through her parted lips
into
the abyss of her heart..

I loose myself into the obscurity of
her eyes.

I often bump into her walking
down the
boulevard of my thoughts.

A few seconds of blissful happiness
and
a few moments of unbearable pain
reminds me of the distance
that separates the heart and the
soul.

Sounds of her uncanny laughter
spills over the windows of restrain.
The secrets of Utopia are revealed
to me,
a sacred gift of unparalleled bliss.

I stand there
on the
threshold of
the horizon,
looking back
upon this
familiar
world...

as I take the leap from this world to
the next,
it is the memories of you that save
me,
save me ever more, ever more...



The Dead of The Night
Sanskriti Nagar
TE IT

Edyukasion

Hardik Shah
T.E. Mech.

I never was a good student
And never intended to be
What I really wanted to learn
Was never taught to me
It was knowledge I wanted
Not just education
I just wanted to test my skills
Not waste time with examinations
I've erred and regretted
I've had my falls
I've faced many hurdles
But have managed to win them all
Now I am my own man
I make my own decisions
Free from this conformist society
And all its myriad restrictions
I try to enjoy myself now
I do not take but give
Now that I have understood
There's only one life to live

SHAKE DA
WORLD...

Rachit Chandra
S.E I.T

Move a bit
The time's come
Pile up your dreams
And stand so firm

Chuck the past
Take a ride
Mock your fears away
Look up with pride

Do not be late
Time will not wait
For the miles that are hardly away
Pay heed to what your conscience
will say

Rock your journey
Show them your worth
Give up the despair
Win all over with mirth.

PHOBIAS

What do people fear most? At the top of the list is death, the fear of which is necrophobia. Second, apparently, is the fear of failure, which is called kakorthaphiophobia. The fear of Friday the 13th is called paraskavedekatriaphobia.

There are fears which you may not know of but they do exist. Some of them are:

- Ageing gerascophobia
- Drinking alcohol dipsophobia
- Becoming bald phalacrophobia
- Becoming angry angrophobia
- Beggars hobophobia
- books bibliophobia
- mirrors catoptrophobia
- standing stasiphobia
- staying single anuptaphobia
- wealth plutophobia
- vegetables lachanophobia
- vomiting, emetics emetophobia
- fear phobophobia



FATE

Nishant Shah

T.E. (Etrix)

Summers of the midforties.
Keeping everyone on ends,
was the Blitz Krieg's fury.

The concentration camps
that Nazis reign,
Had David who grounded in Spain.
Roaming in that Long gown,
But his eyes never frowned.

Admidst these days of pain,
On one midnight hour,
Bevy in the camp resorted to guns,
And the rampage for the freedom had
begun.

Seeing this chaos,
David seized the opportunity,
And started his flight,
To meet his destiny.

Disguising in the dark shadows.
Strolling towards north,
Expedition he started,
With sundial and the malt bread.

Kissing the fields of
Sadistic generals,
And the rape of innocence,
Through macabre he witnessed.

Reaching the fringes,
He crossed the fence.
And his timeless journey,
Thus came to an end.

Militia around him,
Welcomed him to the land.
He waited all these days,
To breathe in his own land.

Hearing the sound of the gun,
Which seemed to be an angel,
And this one bullet,
Scripted his fate.

The short range magnum,
pierced his skin,
And his feeble knees,
Started sinking in.

The last breath he sighed,
With smile he embraced,
Seeking tranquility,
In the laps of his motherland.

Rendezvous With Captain Balbir Singh

Indian Navy

Sohit Raina

T.E.Emx

In the past years, KJSCE has been associated with the two very integral parts of the defence forces: The Indian Air Force and The Indian Army. To complete the trilogy and to add to the invaluable experiences provided by Symphony, this year, as part of Symphony 2006, we had, in our very own campus, the 3rd integral part of the defence forces and one of the most prestigious organizations of the country, the Indian Navy. The Indian Navy displayed their communications systems and the prototypes of the various defence artilleries. While the Navy show was on, I had a short chat with Captain Balbir Singh about his experiences.

Q. Sir, how did u find our festival?

A. Well, it's wonderful. I felt really happy when I came to know that the theme of your event is 'Indian Navy'.

Q. Since you've been associated with Navy for such a long time, what do you think are the positive aspects of joining the 'Indian Navy'?

A. One of the most important aspects of joining the Navy is the fact that you are serving your nation. You might not get this kind of feeling or satisfaction in most of the career options these days. Apart from this, getting into navy means a lot of adventure and of course, there are so many facilities.

Q. Do you feel there are any disadvantages in this job?

A. I personally don't think so. But at the time of joining, people may feel a bit homesick. Nothing more than that.

Q. Any other major drawback?

A. Not at all. In fact as far as the homesickness is concerned, it does not last too long. There are so many challenges to be faced that people are completely engaged in their work. All of us are like a family.

Q. For people like us, as in the engineers, is there any way to get into the Navy after the completion of our degree?

A. Of course there is. In fact we have a proper recruitment process in various colleges across the country; something very similar to your campus recruitment process. Even I have numerous colleges under me.

Q. Where, according to you, does the Indian Navy stand today amongst all the naval forces?

A. Well, I think it is the best Navy in the world. In fact I should say that it is one of the best and the most efficient defence forces in the world.

Q. Sir, any message for the college students?

A. All I want to say is that no matter what your career objective is, keep one thing in mind that it should serve your nation. It need not be necessarily be by joining the Navy or Army. Whatever you do, make sure that your country also benefits from it.

MY FIRST DAYS AT KJSCE

Prerna Shraff

F.E. IT

...being a part of KJSCE gives me immense pleasure as I feel I am a part of a BEE-HIVE where there is work and activity happening throughout the year. It did not take me much time to settle down because the college was as though welcoming me. In the first 3-3 months, I learned about its atmosphere in the college was so good that the traveling problem that existed initially, is now no more. The college has a mixture of so many people of life, there are people coming from far off places, there is a blend of castes and religions and a blend of urban, harbour and central zones.

...the first day, when I entered the college, the main and the first thing that struck me was that this was going to be

the place where I was going to study over the next four years. That was not a matter of concern but ragging was. Luckily I escaped and found out that the seniors were very cordial and friendly. Things became simple further because a lot of seniors helped me sail through and I found a lot of good friends.

There was so much of activity happening in the college that I was always occupied with it and I enjoyed it. Oh! How can I forget the CANTEEN. This is one place where the students can boast of 100% attendance. The canteen is very good and we have a long menu so whenever it comes to eating, I often get confused. As life went on, I got introduced to places like the 'SLOPE', the 'QUADRANGLE' and the 'BADMINTON COURT' (badi as

people call it) where we could see an equal number of people as in the canteen.

The most important discussion in college was about the attendance, the assignments and K.T. was on almost every student's lips. In the first semester, I faced many bouncers and googlies but however, kept myself from not getting out. The HOUSE CUP introduced me to the Cultural and Literary as well as the Sports events. SYMPHONY was an overwhelming experience and I wish some day, I would co-ordinate it.

I hope the college keeps functioning normally and I welcome all the F.E.s.

Hey people in the next issue please keep this column empty as we might have some other F.E.s sharing their experiences.

LIFE AT HOSTEL

Devang A.Vora
CLASS :F.E. IT

Every bright day at the hostel begins at 10 o'clock at night. This is exactly how hostel life can be defined. Packing their baggage from their beloved homes in search for better education, self-dependency etc., the students aboard on board for a journey of life where they reach a station called "hostel". And to everyone's surprise, this strange place, in no time, converts to the most beloved arena for living and then.....the once beloved home is nowhere on the list.

With friends all around, fun and frolic are an integral part of life. For sure, if you are not a "prankster" you would soon become one.

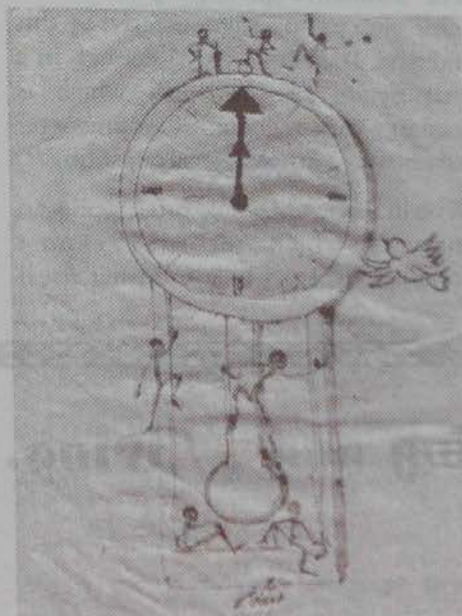

The hostel warden shouting at you for breaking rules, a self restrained ban on touching you, 'educational books' are absolutely a few bounties that you avail of, but mind you they might cost you personally.

And then finally the 'unwanted' morning with a strict message from the rising sun to go to bed.

What about college?

Forget it! Who cares?

Then love it or not, you've got to get out of bed in the afternoon or else the hostel mess will shut its doors for you and you are left with no food but empty utensils for sure!

Then the evening is as usual 'masti time' playing roadside cricket, busy chatting with friends, mind you, not the usual ones at the hostel can be claimed to be a few extra curricular activities in the making.

Then when is study time?

A joke, a mocking question?

We are here to enjoy buddy.

Finally, it's time to bid good bye to the Sun and God and the real hostel life begins.....

BPO Industry

Devang A Vora
F.E. (IT)

The good, bad or the ugly?

Waking up early in the morning to attend college lectures. Chatting and teasing pals around or paying a visit to the most beloved college canteen-----and much more.

This is how a college going student would have described his daily schedule, if one enquired nearly four to five years ago. But as of now, circumstances have changed. The uproar of economic as well as industrial progress is all set to engulf the youngsters, who prove nothing but a "meal of delight" to money makers in the economy.

The bpo industry, which came to the fore in the Indian scenario nearly four to five years ago, has been successful in attracting herds of college-goers to take up responsible jobs at a very tender age. With the changing scenario, college life for the students relating to bpo industry needs to be redefined as well." it's all responsible work for one half of the day while for the other half you are at your own comfort, but at the cost of fun "and" frolic of college life".

In the era of technological

advancement and fierce competition the word "experience" holds the key and for some youngsters and this very word is enough to get them connected to the industry. For some youths, a poor financial family background serves as a key factor relating to their entrance but the ultimate result is that the students lose out on studies which academic results do not conceal for sure. This phenomenon is natural as the tiredness and fatigue accompanied with the job is much more than a teenager can handle. After seven hours of complete exhaustion, do you expect a normal human being to sit back along with his textbooks and study? and that too a teenager. For most of us the reply would be simply "no" then what exactly is driving the students and even to some extent their parents to support this sort of work culture?

The instinctive answer would be the lump sum pay packages offered by this industry. But is this "bait" enough in a vast nation such as ours which is teeming with millions of youngsters? Just answer a simple logical question.

Who in this world would not support an industry which recorded export revenues of \$ 6.3 billion during fiscal

year 2005-06 and if its estimates are to be believed in, it could well soar up to \$8.5 billion during 2006-07. The overall growth rate of 40% relating to the industry could well set all minds blazing and who dares to protest if all these bounties can be obtained from "people still in teens"? As of now, since about 85-90% of the industry is occupied by the college goers there often develops a feeling of commonness among youths who thus share their jobs, sorrows and experience with their so-called "colleagues". This further adds fuel to the ire of college bunks and dropouts.

The major point of discussion still prevails as to whether the prospective education system would let the 'youthful energy' flow in the industrial backdrop or turn the tide towards much needed education. The BPO industry and college life are two utter ends which can never meet and it's high time for the student community to select either of the two. But with recent figures revealing the employment of around 400 people everyday in the industry and the exit as barely 12% of the total workforce, the BPO industry is sure to offer a nail-biting fight to the educationist section of the society.

Dying and Living.....

Jasmine Vyas
F.E. Extc

It's easy to cry that you are beaten and die;

It's easy to crawl and crawl;

But to fight and fight when hope is out of sight

Why that's the best game of all;

And though you come out of each grueling bout

All beaten broken and scared.....

Just have one more try.

Because its dead easy to die

It's the living on that's difficult and complex....



God, Where Are You

Shubha N.
FE-EXTC

through the paths, over the hills
was seeking your presence.
Deep within rivers and the
great valleys,
I was seeking my essence
Oh God! Where are you?
Hiding behind the sky blue?
Waiting for a sight of you,
Hearing even in a cow's moo.
Searched and searched, but

The unending search for the
Almighty
Never ended till my mental clarity.
Then I asked myself 'who are you?'
An inner voice echoed and
Said it's God within me,
Oh! How foolish I am!
That I searched him everywhere,
He is within me, motivating me,
He is now everywhere, wherever
I see.



When....

Jasmine Vyas
F.E. Extc

When opportunity knocks at
your door
Be sure it finds you in
a ready strong and determined
fight, struggle and win
When disappointment knocks at
your door
It is no stranger to you
because it is the best in disguise
knowing that it can change into
When failures storm at your door
Treat them like a man

Give them a consoling word
And a smile if you can
And let me remind you of sorrow
A frequent visitor as long as you live
But his visits grow rare and short
As you learn to share and give
When grumble and revenge are
passing by
and want to rest in you for a while
tell them there's no room at all
For thieves of happiness and smile

Of them all, the best is love
Visitor the best you can ever get
Treat this kind old gentleman
With sincere respect...



India after 60 Years of Independence

Devang a vora

FE (IT)

The age-long shackles of British colonialism broken into bites and bytes, the British "Raj" to continue adamantly in Britain only and the Indian tricolour hoisting prudently and piously in the calmness and easiness of an independent Indian atmosphere. That's what ruled the dream of the patriotic Indians as early as 60 years ago. But since then things have changed and are presently in momentum too.....

The colonial rule of the British was not entirely an "unfortunate" event of the country but a very result of disunity, mistrust and lack of integration of what we call today as "INDIA". As they say "where there is a will there is a way. So the very end of this autocratic rule was to come to an end but sadly after a long span of time or at best an "unforgettable" 200 years of Indian history. The degradation was not only restricted to India's pride but also to the once called as "GOLDEN BIRD", the same India was reduced to a land of poor or specifically "BEGGARS" to the West.

The visionaries often recommend "PAST IS GONE & FUTURE BECKONS US". The same holds true for India. It has risen as a "Phoenix" collecting the reminiscence of the past and joining them brick-by-brick thereby constructing a "modern India", to present to the world society. The problems faced in the Post-Independence period have been numerous. Ranging from poverty, shortage of food, unemployment to illiteracy, almost everything & anything needed to be covered and no single area could be spared. The quantum of task was at maxim and there was no single plan which could prove satisfactory for an over-all development. But "Better begun is half done" and the Indians with their patriotic fervor ensured that all the plans and scheme such as five

year plans, Rural Development Programmes, Several Employment Schemes etc. were right on track as per the stipulated plan period in terms of both quality as well as quantity of performance.

The very result of performance does still reap rich fruits and the "Young Generation" is obviously enjoying the merits of a developing economy which in no span of time would turn into a developed one'. Everyday a new industry sprouts up, new roads are developed, the communication system of the country is on a rampage and how can one forget the growing contribution to the various sectors especially the Service sector, a sector of which an Indian in 1940's might not even had heard of. As far as the predictions go the Indian GDP would catch that of the US latest by the year 2050.

And what else can one demand for.....

"India Shining" the term often associated with our country sometimes mischievously reveals the "darker side" of India more than its outshone glory.

Look at the infrastructure facilities, it's worsening.....

Look at the cultural heritage, it's worsening.....

Look at the population problem, it's worsening.....

Then at times "India Worsening" can truly reflect the true colours of India. Though there has been Industrialization, Modernization but..... at what cost??? At the cost of our culture, our environment or our standard of living? The answer to this is yet to be resolved by the "once Patriotic Indians".

Becoming global is no doubt the need of the hour but there is a lot beyond



globalization that needs to be achieved in the coming future. The will of the Indian government through the implementation of its plans and policies, no doubt plays a dominating & pursuing role but it's time the greatest asset of India i.e. "Human Resources" through their patriotic fervour and a committed effort take the present India further in the 60 years to come.

Seasonings

Words of Wisdom :

He who can not reason is a fool.

He who does not reason is an idiot.

And he who dares not is a slave.

SAY YESS BOSS, BUT CARE FOR JUNIORS

Devang A vora
F.E. IT

Everyone tries to impress his or her boss. The boss determines one's raise, one's bonus and one's promotion. It makes one literally "suck up" to the boss. In the game as to which boss' hot buttons we try to stay on these, we try to put a positive spin on the matters that are close to the boss's heart and we are careful to make our presentations all the credit for success is carefully ascribed to the boss who is capable only of brilliant things. Boss simply never does anything wrong, that is silly. The most of sovereigns are not immune to flattery. So there is no harm in letting your bosses believe that at least in your office they walk on water. I would only say that a happy boss basking in your attention is a necessary factor for your career to move in a positive direction. But it is by no means a sufficient condition. If you really want to progress there are two very important constituencies which one can neglect at one's peril.

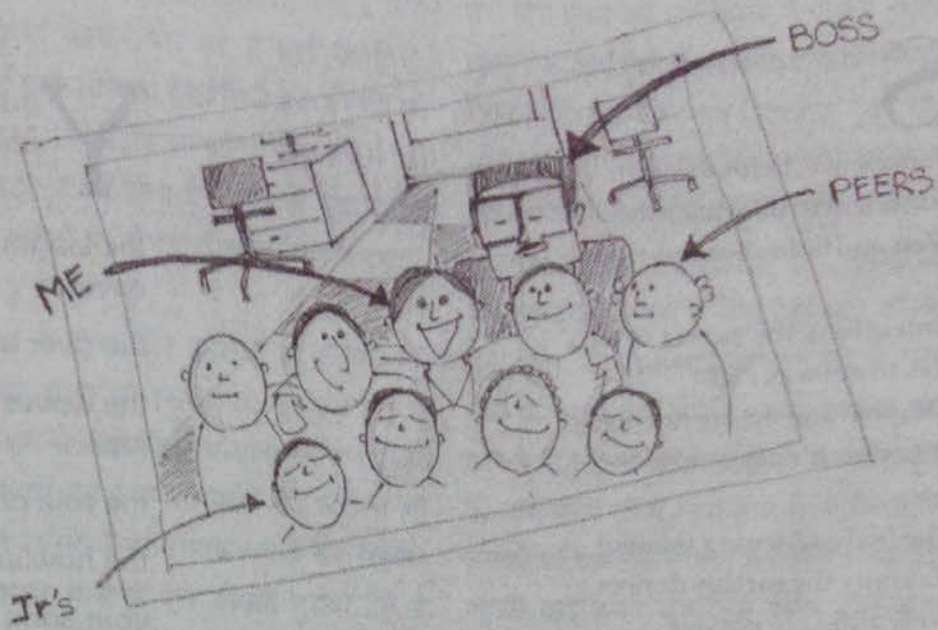

The first group is one's subordinates. They have to respect you. And respect is different from fear or servility (usually driven by....you guessed their selfish consideration!). Subordinates respect you only if they see you as someone who can help them. They do not expect you to know all the details of the job, although such knowledge is definitely a source of respect. They expect you to be in a position to help them when they are in trouble. Nowadays this kind of old-fashioned helping is known as 'adding value'. If competition has cut prices and a person cannot meet goals, you as a manager need to be able to argue for a price cut in your own organization, deliver some

promotion goodies or when needed renegotiate sales budgets. Subordinates dislike bosses who refuse to help. I know interest rates are up, competition is fierce, many things have changed that makes the budget goals virtually impossible to achieve, but these are your problems. As a boss, all I can do is to yell at you and gad you towards unrealistic goals'. Such an attitude is kiss of death. Word gets around .you get placed in a category of 'zero value adds' supervisor. In the short run, your career might not take a hit if you are secure in your position with your boss. Over time, the whole organization learns to distrust you and your special relationship with your boss actually becomes a negative. You are an 'incompetent sycophant'.....and trust me you can forget about the brilliant career.

The second is your own peer group. This is more difficult as they are your natural rivals. But I submit that even though they may not like you, you can and you should earn their respect. They tend to respect deep technical

knowledge and hard work. They tend to be harsh judges, but in many ways they are the fairest and the most useful ones. you cannot fool them with flattery as you can upwards or with fear as you can downwards .from day one in an organization if u work diligently at earning their respect, it pays off in multiple ways .you can actually work on the 'content' of your skills and not just its appearance. You can constructively take their inputs and over time, they become your tough teachers. Over the years, as one's career progresses within one's organization or across different ones, the informal peer network keeps track of you and their words of praise, however grudging, become the best help for your own growth. So boss, of course; subordinates...essential, and peers The real test.



"I"

Shubha N.
FE-EXTC

Stepping up through life,

Conscience, holds us tight.
Conscience, 'us' what's the difference?
Wait and hold your lips tight

Unleashing the power of ego,
Has to get way right
The soul and me are not one
Whether it's day or night

The body adorning the soul
Has only the earthly desires
Body and I are not one
Whether it's day or night

Mortal is the world,
Mortal is the body
Mortal is the materialistic world outside
Immortal is the soul inside

The loop of talent and intellect
Is in the hands of the Almighty
Where is our body adorning the soul
Where is our memory.

Drop the 'I' within you
Blossoming the 'eye' within
Surrender everything at the Lord's feet,
Even the ego as your sin.



God's Song To Me...

Jasmine Vyas
FE. Extc

Your song oh god is the song of the birds
and bees;

the laughter of the rain that cascades down the
eaves;

the river as it rushes through plains and peaks,
the waves as they break on the shores of
seas...

the role of thunder over the hills

the howling of the tempest through the trees

your song oh god is in all things

it is the song of creation

let me ever heed to it

or else I will die of grief...

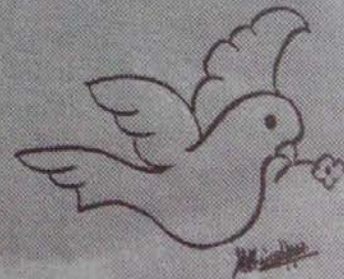

संघर्ष

एक कहानी ऐसी भी

आखिरकार आज जाकर इस दुखद कहानी का अंत हो ही गया। वो कहानी जिसको मैंने अपनी आँखों के सामने घटता देखा। कैसे खुशियाँ आकर पल भर में चली जाती हैं, कोई नहीं जानता। ऐसा सिर्फ हम मनुष्यों की जिंदगी में ही नहीं होता बल्कि पशु-पक्षियों की जिंदगी में भी होता है। ऐसी ही एक दुखद घटना घटी थी सोमैया होस्टल के रूम नंबर - ४०४ में.

आज से कुछ दिन पहले एक कबूतर का जोड़ा आया था इस कमरे में। बड़े प्रेम से परिश्रम से उन्होंने एख घोंसला बनाया। हमारे लिए तो वह एक साधारण सा-घोंसला था मगर उनके लिए शायद सपनों का महल। अकसर विद्यार्थी ऐसे घोंसले तुडवा देते हैं मगर न जाने क्यों यह घोंसला नहीं तोड़ा गया। कुछ दिन बाद कबूतर ने उसमें अंडे दिए। इसके बाद मादा ने बाहर जाना छोड़ दिया सिर्फ नर ही बाहर जाता और अंधेरा होने तक लौट आता। शुरूवात में हमने उन्हें बाहर निकालने की कोशिश की मगर फइर दिल पसीज गया सोचा रहने दो कुछ दिन बाद बच्चे बड़े होने पर अपने आप ही चले जाएँगे। हम रोज ऊपर चढ़कर अलमारी पर देखते कि बच्चे हुए या नहीं। लगभग १५ दिन के इंतजार के बाद दो नन्ही कलियो ने जन्म लिया। यह देखकर जब हमही इतने खुश थे तो उन पंछियों की खुशी का तो कि ठिकाना ही न रहा होगा। मगर उन्हें क्या पता था कि उनकी यह खुशी पल दो पल की ही महमान हैं। तकदीर उनके साथ ऐसा धिनौना खेल खेलेगी, इसकी उन्होंने कभी कल्पना भी न की होगी। उन कबूतरों का क्या कसूर था जिसकी उन्हें सजा मिली। वो पीले रंग के नन्हें, मासूम बच्चे, जिनके अभी तक पर भी न

निकले थे काल का ग्रास बन गए। मगर शायद इसी को काल का जिंदगी कहते हैं.... उस दिन शाम को हम कमरे में पढ़ रहे थे कि अचानक आवाज हुई, चौककर पीछे मुड़कर देखा तो हम सन्न रह गए। मादा कबूतर नीचे मरी पड़ी थी। सर धड़ से अलग! कमरे से बाहर निकलते समय शायद वह पंखे का अनुमान न लगा सकी और अलमारी को टकटकी आखों से देख रहा था। उसका दुख और बेबसता साफ झलक रहे थे मगर मौत के आगे वह कर भी क्या सकता था। अगले दिन हमने देखा तो दोनो बच्चे कबूतर के साथ खेल रहे थे। इस बात से अनजान कि उनकी माँ अब इस दुनिया में नहीं है। उस दिन पहली बार हमने कमरे में कौए देखे बहुत अटपता लगा। ऊपर देखा तो बच्चे ठीक थे। यह काल चक्र यही खत्म न होना था। अगले दिन कमरे में हमें बदबू आई ऊपर चढ़कर देखा तो आखे फटी की फटी रह गईं। दोनो बच्चे चिर-चिर पडे थे, सर कहीं टाँग कहीं। कबूतर भी वहाँ नहीं था। कौन इतनी निर्ममता से इन मासूमों को कार सकता है, हमें कोई आभास नहीं था। शायद कौए??? मगर नहीं। बाद में हमें पता चला कि माँ के मर जाने के बाद कबूतर स्वयं ही अपने बच्चों को मार देता है। यह सुनकर हम दंग रह गए। भला कोई कैसे अपने बच्चों को इतनी निर्मलता से मार सकता है? मगर शायद यही जिंदगी का कडवा सच है। कबूतर को मालूम था कि बिना माँ के बच्चे अब उड़ नहीं पाएँगे अंततः तड़प-तड़प कर ही मरेंगे, शायद इसी लिए.....

अर्चित अग्रवाल
F.E. (Mech)

रचित चन्द्रा

S.E. IT



जिंदगी

जाणता-अजाणता

जिंदगी एक सफर है
टेढ़ी-मेढ़ी डगर है
कभी है अमृत मोड़ा
तो कभी सुहाना जहर है

अनजान है इसकी राहें
अनदेख है सारे मोड़
कुछ पाना है यहाँ
कुछ कुछ खोकर

कभी है ये दो पल की खुशियाँ
कभी है हजारों गमोंकी सदियाँ
कभी रोशनी है ये
तो कभी अंधेरी राह है

खाली हाथ आये थे हम
खाली हाथ हमें जाना है
सीनेमें हो दर्द फिर भी
बाहर से मुस्कुराना है

मुख-दुःख के सायाँ को
हँसकर हमें भुलाना है
अनजान ठिकाने की ओर
अपना कदम बढ़ाना है

शैलजा भरत गावडे
E.X.T.C. T.E.



कितनी चुका झाळा जीवनी
जाणता-अजाणता
त्या क्षणांच्या आठवणीने
फिरतो होऊन जीव-पीसा

त्या जुन्या आठवणीने
मन पुन्हा करपून जाते
पुन्हा पुन्हा त्या वेदनांची
एक खंत मनात सलत राहते

नव्याने उदयास येणारा
अंकुर आठवणीने कुजून जातो
काही आपण गमावले आहे
ही जाणीव देऊन जातो

स्मरून जीवन पुन्हा एकदा
वाढत राहतो आपण चुकलो कसे?
लपलेली काळजाची जखम
वेहऱ्यावर मग स्पष्ट दिसे

जखमी होते मन
जखम पुन्हा ती विघळते
आठवूनी सारे काही
मन माझे दुःखी होते

शैलजा भरत गावडे
T.E. B. EXT.C



जहाज कधी सोडू नकोस...

मनातले गुपित

सुवर्णामुकुटावर उगवतीच्या दवात
भिजली रात्र सरते,
हरवलेल्या वाटीच्या हताश हाती
झळाळीतही धुकेच उरते.

यश म्हणजे खरं अपयशच
खाली डोके वर पाय झालेल
शंकेखोर ढगांचे टवके
चंदेरी साज ल्यालेले
ध्रुवबिंदू असा क्षणांच्या अंतरावर
तरी क्षितिज भेडसावणारच
जिथे संपणार सहदी त्याची
तिथेही इंगा दाखविणारच
थंडीने केला जरी काळजावर धाव
तरी सोडू नकोस वेड्या
मनाचा ठाव

जेव्हा जेव्हा प्राक्तन आणते
ब्रह्मसमंघाचा आव.
तिथेच साऱ्या सृजनदेवता
पडकन घेतात धाव,
हिमविवरात अडकलास तरी
पांढर निशाण रोवु नकोस...
आली दाटून शेवटची लाट,
तरी जहाज कधी सोडू
नकोस...
आली दाटून शेवटची लाट,
... तरी

जहाज

कधी सोडू
नकोस!

(Don't Quit या कवितेचा
मराठी भावानुवाद)
(संकलन : तेजस रविंद्र तुपे)
S.E. - Extc

मनातले गुपित मनातच राहिले
ओठातून काही शब्द फुटले नाही
पण डोळ्यानी अक्षरःस अक्षर टिपुन घेतले.
मुक संबोधनाचे आदानं प्रदान झाले.
पण इतक्याच सगळं संपुन गेलं.
एक मेका ची वाट बघता
जीवनाच्या गाडीला ब्रेक लागले,
मन, मनाचे गुपित
मनातच राहिले.

जसमिन व्यास

F.E. EXTc



नियतीस

Express Yourself

नियती,

तु जरी सोडली साथ,
तरी साथ विश्वासाने सोडलेली
नाही,
बसला आहे जबरदस्त सेटबॅक,
तरी हार अजून मी मानलेली नाही.

असेलही मी अपयशी,
आजच्या या घडीला,
पण छाटू शकत नाहीस तु,
माझ्या स्वप्नांच्या उंचीला.

एकेका अपयशाबरोबर,
जिद्द माझी जागते,
क्षमता साथ देते,
प्रतिभा धावूनि येते.

तुझ्या एकेका धक्क्याबरोबर,
आग माझ्यातली पेटते,
आणि म्हणूनच ती माझ्याकडून,
प्रयत्नांची आहुति मागते.

भळभळत्या जाखामांनी,
धगधगत्या इच्छांनी,
पुन्हा उतरेलरणात मी,
देऊनिया कुरबानी, क्षणभंगुर
सुखांची,
हा डावसुद्धा जिंकेन मी.
छाटून टाकिलपराक्रमाने माझ्या,
त्या वळवळणाऱ्या जिह्या,
फोडून टाकिलसाऱ्या,
त्या खवखवणाऱ्या नजरा,

माहित आहे, काळजावरच्या
जखमा,
भरणार नाहीत लवकर,

पण मीही सोडणार नाही रण,
एवढ्या लवकर.

पुन्हा लढेलमी, पुन्हा चढेलमी,
हजारदा पडलो, तरी पुन्हा
धडपडेन मी,
जिद्दी आहे मी, पिच्छा लवकर
सोडणार नाही,
यश मिळेपर्यंत मीही माझे,
हातपाय कधीच गळणार नाही.

दाखवून देईलसर्वांना,
माझ्या अंतरीची शक्ती,
माझी असलेली,
माझ्या प्रयत्नांवरची भक्ती.

अग, उभार हजार अडथळे,
माझ्या तू धेय्यांभोवती,
मी जिंकणारच हे युद्ध,
जरी हरलो काही लढती.

निषाण माझे रोवणारच मी,
यशाच्या या किल्ल्यावरती,
कवेत घेईलआसमंत सारा,
पाय रोवुनी जमिनीवरती.

येईलघरटया मी परती,
नाव करुनी जगतावरती,
आणि फिरुनी घेईलभरारी,
मी नव्या गगनावरती ...
मी नव्या गगनावरती ...

रक्त सिंचुनी जरी
लिहिलेस कागदावर भाव
मतलब नसतो त्याला
नाही त्याला प्रेम ऐसे नाव

मनातलं सांग सारं
साठवू नकोस काही
जग मग या प्रेमाला
दुजे नाव देई

का राहतोस तू अबोल
का जाणीव तुला नाही
हृदयातल्या वेदनांना माझ्या
थारा उरत नाही.

आठवणी तुझ्या येता
मन रडत नाही
तुला आठवताना मला
रात्र पुरत नाही.

शैलजा भरत गावडे

T.E. B. EXT C

तेजस रविंद्र तुपे
S.E. - Extc



पहिला पाऊस पडतो तेव्हा....

पहिला पाऊस पडतो तेव्हा
एकच काम करायचं....
हातातली काम टाकून देऊन
पावसात जाऊन भिजायचं....

आपल्या अंगावर झेलून घ्यायच्या
बिंबकणाच्या धारा
आपल्यामध्ये भरून घ्यायच्या
बिंबकणारा धारा....

आपल्यामध्ये साठवून घ्यायचे
गडगडणारे मेघ
आपल्यामध्ये भरून घ्यायची
सौदामिनीची रेघ....

पावसाबरोबर पाऊस बनून
नाच नाच नाचायचं
अंगणामध्ये मोग्यापाशी
तळं होऊन साचायचं

आपलं असलं वागणं बघून
लोक आपल्याला हसतील
आपला स्फुटिला झाला
असं सुद्धा म्हणतील

ज्यांना हसायचं त्यांना हसू दे
काय म्हणायचं ते म्हणू दे
त्यांच्या दुःखाच्या पावसांमध्ये
त्यांचं त्यांना कणहू दे

असल्या चिल्लर गोष्टींकडे
आपण दुर्लक्ष करायचं?
पहिला पाऊस एकदाच येतो
हे लक्षात ठेवायचं?

म्हणूनच....
पहिला पाऊस पडतो तेव्हा
एकच काम करायचं....
हातातली काम टाकून देऊन
पावसात जाऊन भिजायचं??!

वरदा कामत

T.E. (Electronics)

कधी 'तू' असा कधी 'तू' तसा

कधी तू असा अबोलकी....
वाटते, शब्द द्यावेत तुला उधार,
की, शब्दांचे वादळ तर नसते तुझ्या मनात?

कधी तू असा बोलका की....
वाटते, तुझ्या शब्दांत वाहून जाईन मी,
की, रित्या शब्दांचे तुझे गुपित मला समजत
नाही?

कधी तू असा शांत की....
वाटते, तुझ्या हृदयात विरघळावे मी,
की, ही वादळापूर्वीची शांतता तर नाही?

कधी तू असा अशांत की....
वाटते, चंदन व्हावे मी तुझ्यासाठी,
की, आगीशी संग मी करत तर नाही?

कधी, तू इतका जवळ की....
वाटते, तुझ्या श्वासांचीही चाहूलघेतेय मी,
की, माझा तुझ्यावर विश्वास नाही?

कधी तू इतका दूर की....
वाटते, तुझ्याशिवाय दुनिया माझी रिती,
की, आपल्यातले अंतर मी मोजलेच नाही?

कधी तू असा कधी तू तसा
वाटतो, तरीही मला हवाहवासा,
की, 'प्रेमा'च्याच 'प्रेमा' त आहे मी?

पण तरीही, 'तू' मला हवाहवासा....
हवाहवासा

वरदा कामत

T.E. (Electronics)

बंदिनी

आजकाल एकतर्फी प्रेमाची सगळीकडे चर्चा आहे.

आजच पेपरमध्ये वाचलं याच्या विरोधात मोर्चा आहे.

मोर्चा काढून, चर्चा करून हा प्रश्न सुटेलकाय?

अशा कळ्या फुलण्याआधी खुडायचे काम थांबेलकाय?

त्यासाठी कडक कायदा हवा.

अपराध्यांना शिक्षा होण्याचा वायदा हवा.

कोणाची तरी मुलगी, बहीण निघून जाते तरी होते का कुणाच्या डोळ्याचे ओले पाते?

सुकी भाषणे, खोटे सांत्वन करून काय मिळणार?

मते, प्रसिध्दी, संस्थांना मदत आणि "इलेक्शनका टिकट"

स्त्री जातीची वाट आहे पहिल्यापेक्षा बिकट.

अपराधी सुटतात, उजळ माथ्याने फिरतात

लफडी केल्याचा शिवका वकीलमुलीच्या माथ्यावर मारतात

मेल्यावरही स्त्रीनेच का झुकतं माप पदरात पाडून घ्यावं?

लाचारीने जगून नेहमी, मेल्यावरही लाचार व्हावं

एवढी बोंब होऊनसुध्दा विधानसभेत प्रश्न जात नाही

तुम्हांला-आम्हांला माहीत आहे, कोण पैसे खात नाही?

अशी कितीतर लोकसंख्या वाढत आहे

मेलेल्यांना जाळण्याची सर्वांनाच घाई आहे

अशा किती लता, नीता, अमृता, रिकू येतील आणि जातील

"पैसे नाही मिळाले तर आपले नेते काय खातील?"

शैलजा भरत गावडे

T.E. B. EXT C

सेटींग

काय करू समजत नाही,

दिवस-रात्र उमजत नाही....

तिच्या मनात काय आहे ते काही कळत नाही,

विचारेन म्हणतो पण गाडी काही वळत नाही.

सिग्नलतर खूप दिले, तिकडे कॅच होत नाही....

बहुतेक माझी फ्रिक्वेन्सीच मॅच होत नाही.

ती पण बघते, मी पण बघतो,

सेटींग मात्र होत नाही,

पण तिला मी आवडतो,

यात काही खोट नाही....

रोहीत चौधरी
T.E. ETRX



चारोळ्या

तुझं माझ्यावर उगाचच उसणं
मनावर माझ्या दुःखाच मळभ आणतं
तुझं नंतर क्षणाच हसणं
लगेच त्याला दूर सारतं.

का कुणास ठाऊक तुला पाहण्याआधी,
माझं लक्ष तुझ्या डोळ्यांकडे वळलं
तू काहीही न सांगताच
तुझं गुपित मला कळलं

चेहरा तुझा सगळं सांगतो
पण मीच त्याचं ऐकत नाही
नंतर तू उदास होतेस
का तेच मला उमगत नाही.

आजचं जग पाहिलं की वाटतं
अगोदरचं जग चांगलं होतं

कारण राजकारण पहिल्यांदा
प्रत्येकाच्या अंगात भिनलं नव्हतं

दुःखःचे वारे संपल्यावरही
डोळ्यातीलपाणी आटत नाही
हृदयात जागा असतानाही
त्यात दुःख साठत नाही.

तुला नेहमी हसत पाहण मला
आवडायचं,
म्हणूनच मग मी ठरवलं
माझ्या सुखासाठी,

का तुझ उमलणारं आयुष्य तुडवायचं?

कभी कभी अकेलेपनमें
नम हो जाती है पलके

दूर कही जंगलमें
बारीश भी बरसे हलके-हलके.

तू रागावलीस की किती छान दिसतेस,
अस नुसतं म्हटलं तरी,
गालातल्या गालात तू गोड हसतेस.

तुझ माझ्याकडे टक लावून पाहणं,
मला सारखं आठवायचं,
मग मी ठरवलं, ते तुझं रूप
माझ्या डोळ्यातच साठवायचं

शैलजा भरत गावडे
T.E. B. EXT C

તું મૈત્રી છે

તું વૃક્ષનો છાંયો છે, નહીં તું જળ છે
ઉઘડતા આકાશનો ઉજાસ છે:
તું મૈત્રી છે.

તું થાક્યાની વિસામો છે, રમણપાટ ની આનંદ છે
તું પ્રવાસ છે, સહવાસ છે:
તું મૈત્રી છે.

તું એકની એક વાત છે, દિવસ ને રાત છે
અયમી સંગાથ છે:
તું મૈત્રી છે.

હું થાકું છું, ત્યારે તારી પાસે આવું છું
હું છલકાઉં છું ત્યારે તને ગાંઉં છું.
હું તને આહું છું:
તું મૈત્રી છે.

તું બુદ્ધ નું સ્મિત છે, તું મીરાનું ગીત છે
તું પુરાતન તોયે નુતન અને નિત છે:
તું મૈત્રી છે.

તું વિરહમાં પત્ર છે, મીલનમાં છત્ર છે,
તું સહી અને સર્વત્ર છે.
તું મૈત્રી છે.

તું સ્વપ્નમાં છે, તું પળ માં છે.
તું સકળમાં છે, અને તું અકળ છે:
તું મૈત્રી છે.

મને ગમે ઇ

મને ગમે જેલ,
ભોગવવી નહિ, જોવી
મને ગમે અશ્વ,
દુઃખના નહિ, હર્ષના
મને ગમે મા-બાપ,
કઠોર નહિ, પ્રેમાળ
મને ગમે બાળકો,
રડતા નહિ, હસમુખ
મને ગમે સ્નેહ,
ક્ષણિક નહિ, ચિરંજીવ
મને ગમે નાટક,
સ્ટેજપરના નહિ, જીવનના
મને ગમે સાધુસંત,
અધર્મી નહિ, ધર્મી
મને ગમે વાણી,
કડવી નહિ, મધુર
મને ગમે સમુદ્ર,
તરવા નહિ, નીરખવા
મને ગમે પ્રીત,
માનવીની નહિ, શેવાળની
મને ગમે ગુલાબ,
કંટકથી નહિ, સુવાસથી
મને ગમે રીઝલ્ટ,
નાપાસનું નહિ, પાસનું
મને ગમે ઈન્ટરવ્યુ,
નોકરીનો નહિ, છોકરીનો.

મૂઠુંગ વોરા
BE (Comp) B

જાસ્મિન વ્યાસ
F.E. E.X.T.C.

સમય

નથી કોઈના હાથમાં રહેતો,
નથી કોઈથી પકડયો પકડાતો,
છતાં, સૌને ડરાવતો રહેતો,
હમેશા એ ચાલ્યા કરતો,
કોણ? કોણ? કોણ?
એ છે સમય!

સમય એક એવી ચીજ છે, જેનો આગળ
માનવીએ ઝૂકવું જરૂર છે.

માનવી અને સમય, બન્ને એકબીજામાં
એટલાં ઓતપ્રોત છે, એ તો આજના
જીવન પરથી આપણે જાણી શકીએ
છીએ.

સૂર્યના આગમન સાથે જ મનુષ્ય, એક
એક કામ સમયને અનુલક્ષીને કરતાં,
આજે જે સ્થિતિમાં જીવે છે, તે જીવન
ઘાંઘલિયું છે, એમ આપણે અનુભવીએ
છીએ. વાત પણ સાચી છે, પણ તેથી
આપણે કેટલા પ્રવૃત્તિમય રહીએ છીએ,
અને આજે જે કંઈ મેળવી શક્યા તે
સમયના સાથથી જ.

એક માનવી, જેને પોતાની આવડત
દેખાડવાની તક મળી છે, પરંતુ તેના
કમભાગ્ય કહો, કે આજસ. તેને સમય
સાથે ઓત પ્રોત થવું પસંદ નથી, એટલે
આપણે તો એને એમ જ કહેવું જોઈએ કે,
“ચાંદલો કરવા આવેલી લક્ષ્મીને તેણે
હુકરાવી” પણ આ તેનું કમભાગ્ય નહી,
પણ સદ્ભાગ્ય હતું. પરંતુ પોતે આજસ
કરી તો સમય હાથતાળી કંઈ ચાલ્યો ગયો
આટલું ભાન થયા પછી પણ જો તે
“જાગ્યા ત્યારથી સવાર” અનુસરે, તો
જરૂર તેને એવી બીજી તક સાંપડે, જ્યારે
તે પોતાની આવડત પ્રગટ કરી શકે.

કહેવાય છે, કે પ્રવૃત્તિમાં રહેનાર
માણસની તંદુરસ્તી સારી હોય, પણ
સાથે એ પણ એટલું જ જરૂરી છે.

કે માનવી પોતાની પ્રવૃત્તિ ગતિશીલ કરે,
જેની વિશિષ્ટતા હોય, મહત્વ હોય, તેમ
જ તેમથી તે નામના મેળવે. પરંતુ જો
મનુષ્ય તેની પ્રવૃત્તિ તેના નિયમિત
સમયમાં પૂરિ ન કરી શકે તો તેનું મહત્વ

કે વિશિષ્ટતા નથી. માટે જ તો કોઈએ
કહ્યું છે કે.

“સમય સમયને માન છે”

આજે જે કાર્યની જરૂર છે તે કાર્ય આજે ન
કરતાં, વર્ષો બાદ કરીએ તો તેની કિંમત
થોડે ઘણે અંશે ઓછી તો થાય જ છે.
ક્યારેક આજે મૂલ્યવાન ગણાતું કાર્ય,
સમય પસાર કરવાથી ઘૂળ બરોબર થઈ
જાય છે.

આમ સમય એ એક મૂલ્યવાન ચીજ છે,
અને તેની સાથે ચાલવાના કાયદા પણ
આપણે જાગીએ છોએ, તો પછી શા
માટે સમયને ઠોકર કંઈ એની પાછળ
ચાલવું?

મૂંઝંગ વોરા
BE (Comp) B

ખરાં છો તમે

ઘડી માં રિસાવુ, ફરીથી મનાવુ,
ખરાં છો તમે

હજી આવી બેઠાં, ને ઉભા થયા
અમારાથી આવું
ખરાં છો તમે

ન આવો છો મળવા, ન ઘરમાં રહો
અમારે ક્યાં જાવું
ખરાં છો તમે

ન પુછો કશુંએ, ન બોલો કશું
અમસ્તા મુંઝાવુ
ખરાં છો તમે

હતી ભાગ્ય રેખા, ભુંસાઈ ગઈ
ખરાં છો તમે

જાસ્મિન વ્યાસ
F.E. E.X.T.C.

ન શક્યા...

સાથે મળીને અમે એટલું કર્યા,
 કે એકલતા અમે જીરવી ન શક્યાં,
 મહીયા કર્યા ને અમે ત્યાં તો રમ્યા,
 ક્યાથીએ અમે પાછાં ન પડ્યાં,
 આનંદ માણ્યાની મજા એવી હતી,
 કે આજે પણ અમે એ ભૂલી ન શક્યા.
 મોજમજામાં બચપણ વીતાવ્યું,
 ધીંગામસ્તીમાં વીતાવ્યું યૌવન,
 ઘડપણને આંગણે આવી પહોરથા,
 પણ વીતેલો પળો ખંખેરી ન શક્યા.
 આવો, આવજોમાં રહી ગયાં,
 સ્નેહી આવીને લઈ ગયાં,
 હુંટાઈ ગયા પણ એવી રીતે,
 કે જાંદગી આખીયે તરી ન શક્યા
 સાથે મળીને બહુ કાર્યો કર્યા,
 કે એકલતાએ હિંમત દાખવી, ન શક્યા.

મૃદુંગ વોરા
 BE (Comp) B

ઘારો કે

ઘારો કે એક સાંજ આપણે મળ્યાં અને આપણે હળ્યાં
 પણ આખા આ આયખાનું શું?
 ખુલ્લી આ આંજ અને કોરી કિતાબ,
 એને ફરીફરી કેમ કરી વાચશું?

માનો કે હાઠે રહેજ મ્હીરી ઉઠયા ને છાતીમાં મેઘધનુષ ફોશિ
 ઉઠાય
 પણ બળબળતી રેખાનું શું?
 આકાશે આમ કંયાક સુકી લીધું ને ફુલોને કેમ છો? પૂછી લીધું
 પણ મૂંગી આ વેદનાનું શું?

માનો કે આપણે ખાધું-પીધું અને માનો કે રાજ! થોડું કીધુંયે
 રાજ પણ મૂરતા આ ઓરતાનું શું?
 ઘારો કે રાણી! તમો જીતી ગયાં અને ઘારો કે વાયરા વીતી
 ગયાં પણ આ માંડેલી વારતાનું શું?

જાસ્મિન વ્યાસ
 F.E. E.X.T.C.

તમે કહો

તમે કહો તો હાં અને જો નાં કહો તો નહીં
 અમે તમારે કોરે કાગળ, કરી ઘઈએ સહી,
 તમે કહો કે ચાલવું છે, તો રસ્તો થઈને ખૂલશું,
 તમે કહો કે ભુલવું છે, તો યાદ કરીને ભૂલશું,
 મીરાની મટુકીમા માધવ; હોય ન બીજું કંઈ,
 તમે કહો તો હા, અને જો ના કહો તો નહીં.
 તમે કહો કે નહીં બોલો, તો હોઠ ઉપર છે તાળા,
 ભીતરમાં તો ભલે થતી રહે, નામતણી જળમાયા.
 તમે કહો કે સાથે રહો, તો અમે જઈશું રહી,
 તમે કહો તો હા, અને જો ના કહો તો નહીં.

જાસ્મિન વ્યાસ
 F.E. E.X.T.C.

मातृभाषा की कहानी, उन्हीकी जुबानी

“भाषा, मातृभाषा, language” शब्दो तो धझा बधा પણ પર્યાય એક જે ભાષા એટલે આપણા સંસ્કારની વાશા! અપને આदर्शों की बोली!

language is the way to express oneself!

આ ભિન્નભિન્ન ભાષાના શબ્દો સારા તો છે પણ તેમાં કાઈક ખોટું લાગે છે, નહીં!! જે માંડુ analysis wrong નથી તો આ ભાષાઓનું fusion આજે થઈ common છે. આપણા કાનને “remix concept” ની એટલી બધી આદત પડી ગઈ છે કે હવે તે એની જ ધૂનમાં રહે છે. થોડાંક વર્ષો પૂર્વે, આ ભાષાઓને જે સ્વતંત્રતા અને અનુકુળતા મળતી હતી, તે આજે ક્યાંક તો ભારતની વધતી આબાદીમાં ઓવાઈ ગઈ છે. એટલે જ મને વિચાર આવ્યો કે જેમ આપણને આ democratic country માં freedom of speech મળે છે તો આ ભાષાઓને કેમ ન મળે? તો પ્રસ્તુત છે, જૂદીજૂદી ભાષાના આંતરવિચારી:-

ગુજરાતી બોલે છે: “માહું ગૌરવ ગુજરાતી ચાલુ થયું એ વાત તો ખરી, પણ હવે તો મારી ગુજરાતી પણ મારો સાથ છોડતી નજરે ચડે છે. જોકે તેમાં એ લોકોનોયં વાંક નથી. ધરના લોકોની ભાષામાં ગુજરાતી અને અંગ્રેજીનો જન્મ થયો છે : “ગુંગલિશ”. આ નવી ભાષાએ મારા શબ્દોની મીડાશને ઓગાળી નાખી છે. પણ કહાય કહલાતાં જમાના પ્રમાણે બદલાવવું આજે અત્યંત જરૂરી બન્યું છે. બસ, રહીરહોને દિલમાં એક જ વાત આવે છે હે તમે આ

“ગુંગલિશ” ભાષામાંયો ગુજરાતીને ગાળીને, એને ફક્ત ઇંગ્લીશ તો નહીં બનાવી હો ને?”

હિન્દી ને કહા : “કહને કે लिए तो मैं सभी मातृभाषाओंसे बड़ी मानी जाती हूँ लेकिन क्या मेरा अस्तित्व आज भी टिका हुआ है? लोगोंने मेरे शब्दोंकी नजाकत को ऐसे मरोड़ दिया है कि आज मुझे एक नयी पहचान मिल गई है : “मुंबईया हिन्दी”. आजकल मैं गुंडो की भाषा बोलने लगी हूँ। आम जनता को भी पता नहीं क्यों पर इस मुंबईया हिन्दी की आदत सी हो गई है। और तो और, मेरी भाषाका प्रयोग आज अंग्रेजी के साथ इतना बढ़ गया है कि लोग आज “हिंगलीश” बोलने लगे है। मुझे तो डर है कि भविष्यमें लेखक/लेखिकाओ और कवि/ कवयित्री के कलम की मौताज़ बनके नारह जाऊँ!!

મરાઠી મ્હણાલી કી : “મલા વાટતે કી માઝા વાપર આતા વાઢલંચ. જ્યાંના મરાઠી ચેત નાહી તે પળ માઝા વાપર કરતાત. પળ માહિત આહે કશાસાઠી? “આઈ ગં” યા દોન શબ્દાસાઠીચં. યા દેશાચા એકા પ્રગત રાજ્ય મહારાષ્ટ્રાચી માતૃભાષા અસૂનહી ત્યા દરજ્યાચા થોડાસા હી અનુભવ મલા આજ મિલ્લત નાહી. સ્પર્ધેચ્યા અધિકારીક વાપન્યાને માઝીચ માણસં મલા મરણ યાતના દેતાત. મુંબઈ યા આર્થિક રાજધાનીમધ્યે મલા હિન્દી બરોબર મિસલૂન માઝાં અસ્તિત્વચ “મુંબઈયા હિન્દીમધ્યે” બદલલંચ. વાટ લાગલી, નંતર કાય? મલા આતા એકચ ખિતી સતાવતેય કી પુઢચી પીઢી મલા “આઈ ગં” યા દોન શબ્દાંસાઠીચ મર્યાદિત ઠેવેલકા?

Isn't it ironic that we were forsaking our mother tongue, to master a foreign language! It is this that we use as a stepping stone to learn English! I Fear that one day our language will eventually die, being relegated to languages which are more globally accepted. It's time our generation realises this and resurrects our near defunct languages. Having said that, I sincerely hope that any future regional language column in Kshitiij never goes blank.

રિધિ શાહ

TE (Comp)

Marathi Translated by

Hrishikesh Sathe

(TE Comp)



Vivek Bhalekar
B.E. Mech

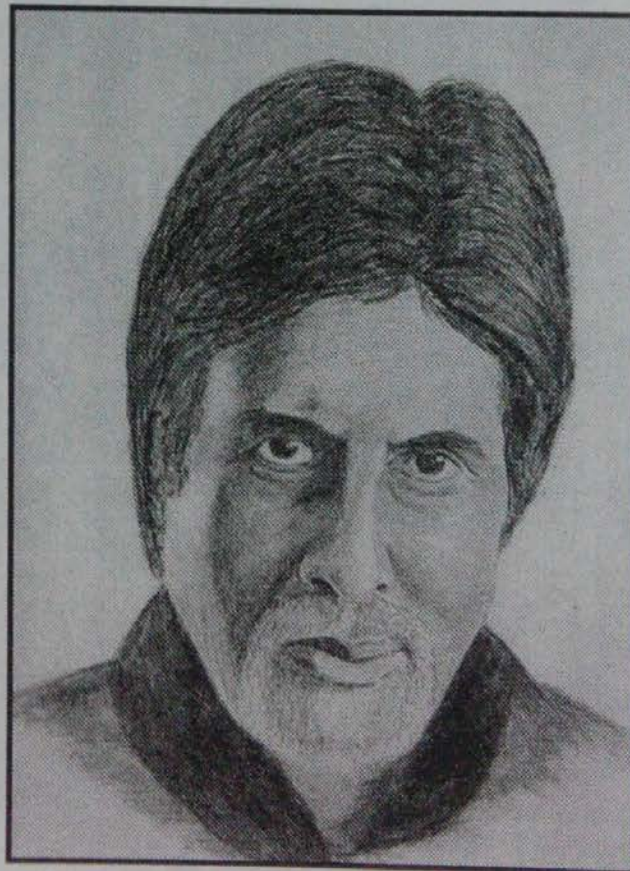
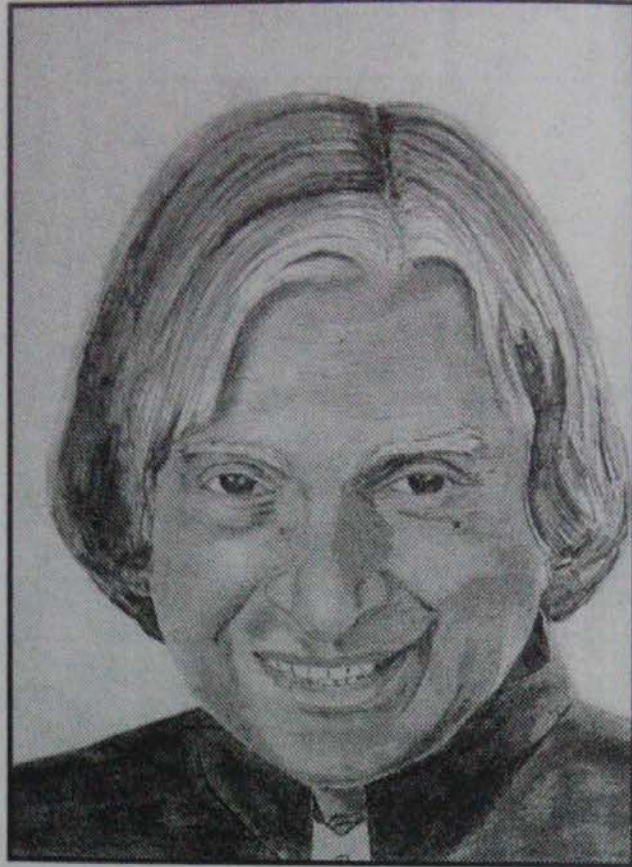

Niraj Walchale
S.E. Mech

ये नहीं होते तो....

सफलता में केवल विद्यार्थियों, आपको और कार्यकर्ताओं का हाथ नहीं के कर्मचारी, परीक्षा विभाग के कर्मचारी, कैंटीन के कर्मचारी, लैब कर्मचारी, वर्कशॉप के कर्मचारी इन सबकी मदद हमारे रोजमर्रा के कामों और हमारी सफलता में बहुत महत्वपूर्ण है। दुःख की बात यह है कि बहुत कम लोग इस बात को समझते हैं। हमने कुछ ऐसे लोगों से बात की और उन्हें आपके समक्ष लाने का प्रयास किया है।

हम आशा करते हैं कि आप भी इन लोगों को पहचानें और इनको सराहे क्योंकि ये नहीं होते तो....

पहला साक्षतकार (इन्टरव्यू)

नाम : जयंत शेट्टी

पता : वानलाली ना, सांताक्रूज़ (पू),

काम का समय :

७.३० सुबह से शाम

६.३० तक

काम : कैंटीन में पैसे संभालना



प्र : आप इतने पकवान देखते हो, लिखते हो, तो आपका मनपसंद पकवान कौन सा है?

उ : डोसा

प्र : अब बहुत सारे विद्यार्थी कूपन लेने के लिए यहाँ जमा हो जाते हैं, तब क्या आप गुस्सा होते हैं।

उ : कभी कभी।

प्र : जब नए पकवान बनते हैं, उन्हें सबसे पहले कौन चखता है?

उ : हम सब चखते हैं, या फिर छात्रों को चखने के लिए कहते हैं।

प्र : कभी किसी विद्यार्थी ने कोई बदमाशी की है, जैसे कम पैसे दे कर ज्यादा पैसे का ऑर्डर लेना या फिर यह बोलना कि मैंने कूपन दिया था?

उ : नहीं, ऐसा भी कभी नहीं होता है। बस एक बार एक विद्यार्थीने ऐसा किया था पर हमने उसको समझाया और फिर वह मान गया।

प्र : यह सब खाना कब और कितने वक्त में बन जाता है?

उ : सुबह १०.३० से ११.३० तक बन जाता है।

प्र : कौन तय करता है कि कौनसी सब्जी बनेगी, क्या खाना बनेगा?

उ : रसोइघर के मैनेजर "हरीश" तय करते हैं खाने में क्या बनेगा। वो दत्ता को संभालता है जब वह गुस्से में आ जाता है, जब बहुत सारे विद्यार्थी जमा हो जाते हैं।

प्र : जो विद्यार्थी आपके दोस्त बन गए हैं वे आपको कहते होंगे ना कि कुछ मुफ्त दो या छूट दो?

उ : हाँ काफी विद्यार्थियों के साथ मेरी अच्छी दोस्ती हो चुकी है और वे मुफ्त में माँगते हैं, पर मैं नहीं दे सकता क्योंकि मेरे उपर भी मेरे बाँस है।

प्र : तो कौन-कौन काम करते हैं यहाँ?

उ : दत्ता- ऑर्डर लेता है

जितेंद्र - चाइनीज बल्लेबाज

सतीश - डोसा बगल

कृष्ण - सैडविच बनाने

शेट्टी - मालिक।

प्र : दत्ता, कभी ऐसा होता है कि आप ऑर्डर और कौन ले जाता है?

उ : ऐसे कैसे ले जाएगा, जिसका पता पता जाँच जाएगा ना। मैं सबके ऑर्डर रखता हूँ और मुझे पता होता है कि किसका ऑर्डर कौनसा है, चाहे कितने भी विद्यार्थी हो।



दूसरा साक्षात्कार (इन्टरव्यू)

नाम : मारूती चीले

पता : घाटकोपर
(प)

काम का समय -
सुबह १०.०० से शाम
६.०० तक



काम : झेरॉक्स और सफाई

प्र : आप कितने बजे आते हैं और क्या काम करते हैं?

उ : मैं १० बजे आता हूँ और सबसे पहले कक्षाओं और प्रयोगशालाओं को साफ करता हूँ। फिर ११ बजे से झेरॉक्स और फिर से शाम को सफाई करता हूँ।

प्र : आप कबसे इस कॉलेज में काम करते हैं?

उ : २००१ से। पहले एक साल सफाई की और २००२ से झेरॉक्स संभालता हूँ।

प्र : रोज कितना झेरॉक्स निकालते हो?

उ : १५०० कॉपी एक दिन में।

प्र : क्या आपकी किसी ने कभी शिकायत की है?

उ : नहीं ऐसे तो किसी ने कभी शिकायत नहीं की, पर एक बार एक छात्र ने शिकायत की थी क्योंकि मैंने उसके २५ रुपये नहीं दिए। पर जब मेरे पास छुट्टा हो जाता, तब मैं उसको देने वाला था।

प्र : आपका विद्यार्थी के साथ कैसा संबंध है?

उ : अच्छे संबंध है, झेरॉक्स लेते समय, खड़े-खड़े बात करने लगते हैं और फिर दोस्ती हो जाती है।

प्र : अगर कोई छात्र पैसे नहीं देता, तो

आप क्या करते हैं?

उ : मैं अपने पैसे से करके देता हूँ, अच्छे छात्र बाद में आकर पैसे दे जाते हैं और कुछ छात्र नहीं देते हैं। चलता है।

प्र : क्या आप कुछ गडबड़-घोटाला करते हैं?

उ : नहीं मैं कुछ घोटाला नहीं करता। यहाँ एक रजिस्टर होता है जिसमें रोज कितना झेरॉक्स किया, वो लिखना पड़ता है। अध्यापकों के लिए एक अलग रजिस्टर होता है।

प्र : आपको छात्रों की क्या बात अच्छी नहीं लगती है?

उ : कोई छात्र काम आने पर अच्छी तरह बात करते हैं, और काम हो जाने पर कभी-कभी पीछे से गाली देते हैं। पर सब छात्र ऐसे नहीं होते।

तीसरा साक्षात्कार (इन्टरव्यू)

नाम : जानू कंजी
और रीना
तिवारी

पता : चेम्बूर और
उल्हासनगर

काम का समय :
सुबह ९ बजे से शाम
५ बजे तक

काम : सफाई और ऑफिस का काम

प्र : आप कब से काम कर रहे हैं और क्या काम कर रहे हैं?

उ : जानू - १९९७ से

रीना - १९९० से

सुबह ९ बजे से लैब और कक्षाओं की सफाई, उसके बाद ऑफिस का काम जैसे फाइल संभालना, पेपर पर छाप



लगाना आदि।

प्र : छात्र कैसे हैं और आपको उनकी क्या बात अच्छी लगती है?

उ : छात्र सभी अच्छे हैं और जब वे पास होकर अगली कक्षा में जाते हैं तब भी हमसे दोस्ती रखते हैं, मिठाई देते हैं, हमें वो अच्छा लगता है।

प्र : रीनाजी आप १७ साल से काम कर रही हैं, क्या-क्या बदला है अब तक?

उ : सब कुछ बदल गया है। तब तो कैन्टीन भी नहीं थी, लिफ्ट नहीं थी, पानी की समस्या होती थी, प्रिण्टिंग भी अच्छी नहीं थी, छात्र भी बहुत कम थे।

प्र : आपके काम की जोब कौन करता है?

उ : अशोक सर जाँच करते हैं, वो हमें बहुत हँसाते हैं पर कभी-कभी बहुत सख्त भी हो जाते हैं। वो बहुत अच्छे हैं।

प्र : अध्यापक कैसे लगते हैं?

उ : बहुत अच्छे हैं, हम उनका काम भी करते हैं, कभी-कभी हमारी मर्जी से क्योंकि वो हमें अच्छे लगते हैं।

प्र : आपकी आज तक किसी ने शिकायत की है?

उ : नहीं

प्र : आप इस कॉलेज से और अपने काम से खुश हैं?

उ : बहुत खुश हैं।

प्र : आपको छात्रों को कुछ कहना है?

उ : कक्षाओं और लैब को साफ रखें।

रिचा पारेख, रेनुज परमार,
ईश्वरी वखारिया
T.E. Camps

Students' Council 2006-07



RAJAPRIYA SAMBANDAM (General Secretary)

The first lady General Secretary of KJSCE in 24 years! Doesn't that speak for itself? She's the brain behind the Freshers' Eve (which was given a sabbatical for two consecutive years before ours), the House Cup and Symphony. A great leader who has been able to keep the council united and strong which has carried on even after their tenure. She's known to be a 'rice' reservoir as there's hardly been a day when she's had something else for lunch!

Mom speaks: "It was a day after the 1993 Bombay bomb blasts. In the morning, we did not know that the schools were going to be closed, so we went to the bus stand. But by the time we reached, the bus had left empty, announcing that the school was closed for the day. But my daughter was convinced that we came late and missed the bus. Since she was very regular and never missed a single day at school, she never knew she could miss school on weekdays. She started crying loudly and refused to come back home. I failed to convince her. Finally, I had no choice but to take an auto to school to show her the closed gates."



NISHANT SHAH (Joint General Secretary)

The Infra Chief from the council who is usually seen roaming around in college, being bossy (or pretending to be bossy) with a chocolate/biscuit in hand catching somebody or the other to do his work :-). On a more serious note, he's been the man behind the infra and security planning and the one ensuring the smooth running of all events. Whether it's the police permissions, the pronite or the organization of events, this guy has been at the forefront since the very beginning. Contrary to his looks, he's one of the most dedicated members of the council. The only word he believes in is, 'believe'. A complete foodie, he lives to eat!

Friend speaks: "Once Nishant and I were playing in a football match and I was a member of the opponent team. He was the goal keeper of his team. I was at the goal and I made all attempts to strike a goal, but every effort went in vain; not because I wasn't good enough. Anybody else would not have been able to either when the goal post was completely covered!"



SHASHANK MOOLYA (Joint General Secretary)

This Joint General Secretary is one of the most friendly and approachable persons around. He was entrusted with the job of the Marketing Chief and he lived up to all our expectations. He always ensured that the council worked as a team leaving all differences aside. He has a huge appetite. Chicken almost came as a surprise and especially when it comes to chicken!

Friends speak: "He is the most hard-working person you can meet at work and the most fun & easy person you can meet at a party. He surely knows how to live life king-size. He spreads warmth wherever he is among strangers."



SHARANYA SANTHANAM (Cultural Secretary)

The creative genius of the council! She comes up with the names for the events and she's the one who names for them. Hats off to her for her able guidance in the field of drama which helped the council break university records! The success of Dramatica was a result of her dedication and perseverance. Her creativity even extended to the field of art where she's known to have named each of the six puppies in the quadrants: Blue, Red, Green, Yellow, Black, White. In her excellent moods, she can be seen singing and swaying around and even dancing a crowd of people.

Sister speaks: "Sharanya was a mischievous kid. When we were in the kitchen while playing hide and seek, she climbed to the top shelf of the cupboard and lurched her head in. She hid patiently. She wasn't scared of being all alone. But as I said, she was a mischievous 'kid'; she hid in the same place every time we played."



SAQIB KHATIB (*Joint Cultural Secretary*)

Whether it's singing, dancing or the guitar, he knows it all and is adept at them too. He's done a commendable job organizing the Fashion Show and the Amateur Band Competition. He's one of the best competes in college; the way he anchored the Fresher's Eve and Gyration is worth mentioning. He is perhaps one of those guys who would always be ready to do anything. A friendly and an easy going person, Saqib is an infinite source of energy and is extremely popular with the girls!

Friend Speaks: "This guy has amazing levels of energy in spite of his pitiful frame. He is quite dynamic. A complete extrovert, he tries to reach out to people around him bringing the best

in them."



KARTIK SRINIVASAN (*Joint Cultural Secretary*)

Jt. Cultural Secretary junior slowly and steadily pulled in the crowd for Symphony as Publicity Head. He has aptly played the role of an SE in the council with significant contributions in the cultural team, publicity, judges, transportation etc. He's a cheerful guy with an admirable amount of enthusiasm for his work.

Friends speak: "He is the only guy who can compare a telephone conversation with wavelengths and frequencies. He also cracks amazing PJs. Don't travel with him by auto coz he is hardly the one to pay the bills."



PRANSHU SHARMA (*Sports Secretary*)

He's one of the most popular people around, both in and outside the council. The Sports Secretary was the main person responsible for the house cup and most of the sports events round the year. He brought in the adventure sports- rappelling, valley crossing etc for Symphony. He's also an active member of his class when it comes to bringing in the people together and even the pit decisions (which are yet to be implemented;-) He can be easily spotted in a crowd by his 'not so hot' head!

Friends speak: "Pranshu is characterized by his craving for cutting (chai), his low waist jeans, the hostel and the computer department T-shirts. A Bryan Adams fan with the unmistakable red phone which he refuses to part from; He's indeed an amazing person and a friend to cherish."



RISHI MALIK (*Joint Sports Secretary*)

The sports' ace of the council! He effectively performed the selections for the University sports events. He utilized the talents of our sportspersons to their optimum potential. A joyful person who is seldom without his characteristic baseball cap!

Friends speak: "Rishi had gone to an amusement park in the U.S. He was waiting in line for a ride, with his brother in law and sister. He was probably too preoccupied with his own thoughts to have noticed a local resident, asking him for the time. He took almost 10 minutes to realize that his brother-in-law had already complied with the needs of that young lad. When asked, Rishi told his brother in law that the wrist watch that he was looking at, was set according to the IST. and so all the while, he was trying to zero down to the possible timings by using his mathematical ingenuity."

Is that what engineering does to people or is that just Rishi??



AASHISH SHETH (*Joint Sports Secretary*)

One of the Joint Sports Secretaries and also an Infra Co-Chief! He filled up the void for the absence of sports events in the odd semester with a successful Monsoon Cup. His contributions have been monumental in the success of other sports events throughout the year. A quiet but a friendly person, he stands out with his innocent face and his husky voice.

Friends speak: Aashish has not bought a single text book in his four years of Engineering and has yet managed to score 70% every time. This is "Something" for the juniors. Had Aashish not been an engineer, he would have surely been an actor. And when he is not acting, you will find him asking things like 'kyon' and 'kidhar'.



SUKANYA RAJKHOWA (*Magazine Secretary*)

Sukanya is perhaps one of the most sincere members of the council who habitually does things in a very efficient and professional manner, and also sometimes makes others do it that way. Quality is what she loves and delaying work is something she hates. She indeed had a mission to bring out this magazine in record minimum time (which finally has been accomplished!!!). Though a bit absent minded, most of the new ideas of the magazine are thanks to this lady.

Sister speaks: "She is probably the only existing soul in the world who has been gifted with what her family and friends call "a second voice" (she talks even when she has a soar throat)."

Friend speaks: "Sukanya's careful attention to work leaves her absent minded in often embarrassing

ways; she once vented out her anger and complaints about poor delivery and bad service at someone outside the hostel thinking it was the tiffinwala, only to realize later that he too was a fellow hosteler waiting for his meal."



SOHIT RAINA (*Joint Magazine Secretary*)

Literary events, publicity, food committee.. He's played an important part in almost every department of Symphony! He's very passionate about the Kashmir issue and terrorism and his opinions are well respected amongst his peers. A prolific writer and an equally eloquent orator, he has added a refined touch to the magazine committee. He's not the one to be known for his looks, but behind his innocent looks, there could be a 'not quite innocent' Sohith!

Friends speak: "He has a fascination, an obsession for whatever he does. Planning the events which eventually fail to take place is his forte. Networking with other students, irrespective of them being seniors or juniors is like a hobby to him. If you ever want to see him portray a theatrical song, you

should just see him in conversation with any of the faculty members or the administrative authorities. I am sure he plays a major role in all the council discussions which bear no outcome. He believes in never disappointing anyone and thus he is the best friend of everyone. All in all, a decent chap and a natural charmer!!!!"



RUTVIK SHETH (*Joint Magazine Secretary*)

The junior Joint Magazine Secretary has been very efficient in the literary as well as the sports teams. Whether it's organizing debates, quizzes, writing letters or designing posters, he has mastered them all. But he does everything at a price. And that's not money. It's food. His passion for food has no bounds; even two days before the magazine printing began, a glut of biscuits and biscuits was enough to distract him. A very jovial and popular member of the council.

Friends speak: "Someone who perhaps knows the entire Oxford Dictionary of English is a sharp olfactory! Open the lunch box and within a second, he's standing by your side, sniffing the crumbs of food behind. Despite all, he's one of the sweetest friends one can have."



TOJO THOMAS (*Public Relations Officer*)

Joe, that's how he's known! As part of his job of the Public Relations Officer of the council, he was the Media Chief for Symphony. The publicity that Symphony received amongst the print and the web media has been a result of his diligence. He played a vital role in bringing in the bands for the promite. He has also been an active member of the FSAE team which made the race car. He's one of the very few to remain calm and composed even during the convoluted discussions of the council.

Friends speak: "An idle mind is a devils' workshop. This is the motto of Tojo's life. You will always find him running for something or nothing. A completely creative and hardworking person, he excels in every task he takes up. He is very simple with no pretensions and what will take him far in life are

truly his patience and calm nature."



RIDDHI SHAH (*Student Representative for Alumni Interaction*)

The Alumni interaction has been strengthened to a large extent because of her sincere efforts. She brought in Alumni as sponsors, judges for our events and even as writers for Kshitij. As a Marketing Co-chief, she has made the small contributions sum up to an impressive total without a single contact. A very dedicated and a disciplined worker! She's distinctively recognized by her voice and her queer phrases such as 'fresh books'!

Friends speak: "Riddhi's sense of humour is one of a kind. Its peculiarity lies in the fact that she is unaware of the hilarity. Once, Riddhi was giving directions over the phone to her friend who was in the bus. She said, " You want to go to the mall right, when you reach the signal just tell the bus

conductor to take a right."



MONIL GANDHI (*Treasurer*)

The council's most sought after person! Whether it's any event or a prize or taking care of transport, food etc, we turned to him for almost every small thing...not because he's the smartest but cuz he was in charge of the most important department...MONEY.. He kept a count of all the money and wouldn't even leave the coins. He has other dimensions to him as well which are equally sought after..(this time, the factor is 'him', not something else!!) He's been the technical brain behind Symphony and has also put up a breath taking line up of cars and bikes at the Auto Expo for Symphony. He's also blessed with good aesthetic sense which is evident by his designs of the Symphony brochures and even the cover page for this magazine.

Friends speak: ". He eats and eats and eats and denies eating too much! But that shows in his perfect physique (not to forget, he apparently hits the gym regularly!). He'll make plans with everybody. At the same time, he'll make plans with 25 people. Smart strategist as if one plan doesn't work out, he always has a backup! Last but not the least, he is always there when anybody needs him. He will not think twice before helping. And you will never feel like a stranger before him...unless it's a pretty girl, as he'll feel shy in the beginning!



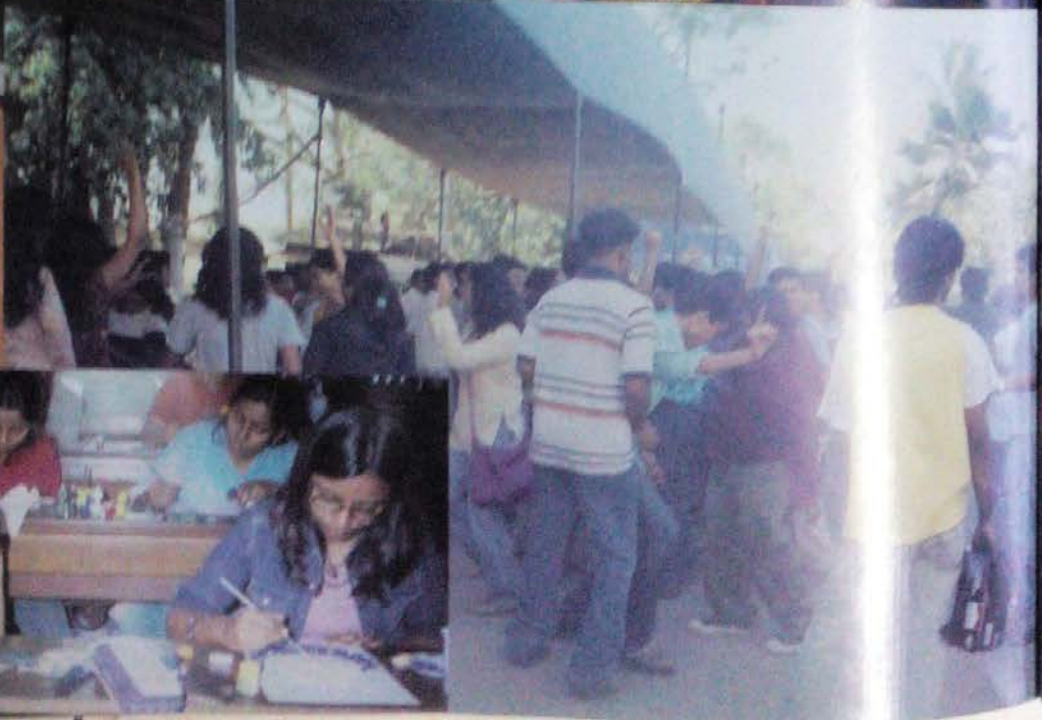
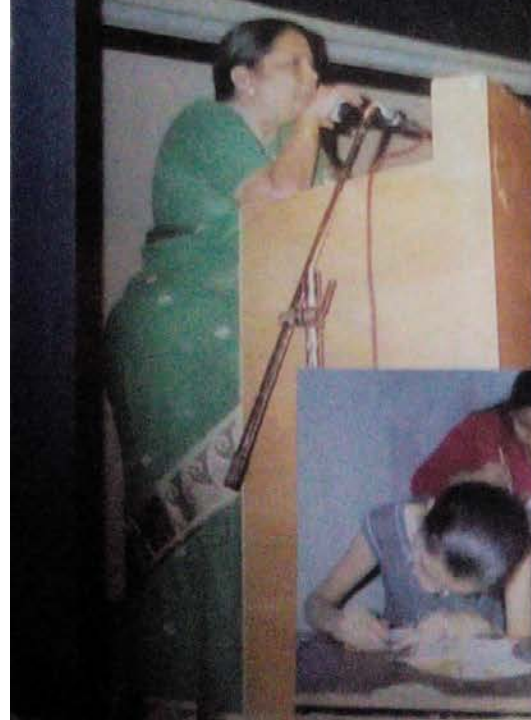



The HOUSE CUP introduced me to the Culture
ary as well as the Sports events. SYMPH
overwhelming experience and I wish some
co-ordinate it.

All friends all around. fun and frolic are
art of life. For sure if you don't
know? you would soon become
that great?

hostet warden shouting at you for
a self restrained ban on touching you

Cover Designed By Mohan Gandhi
Printed at The Book Centre 2007